

# Lift overview

(Cutout dimension see sheet 2, forces see sheet 3  
detailed installation information, see separate instructions)

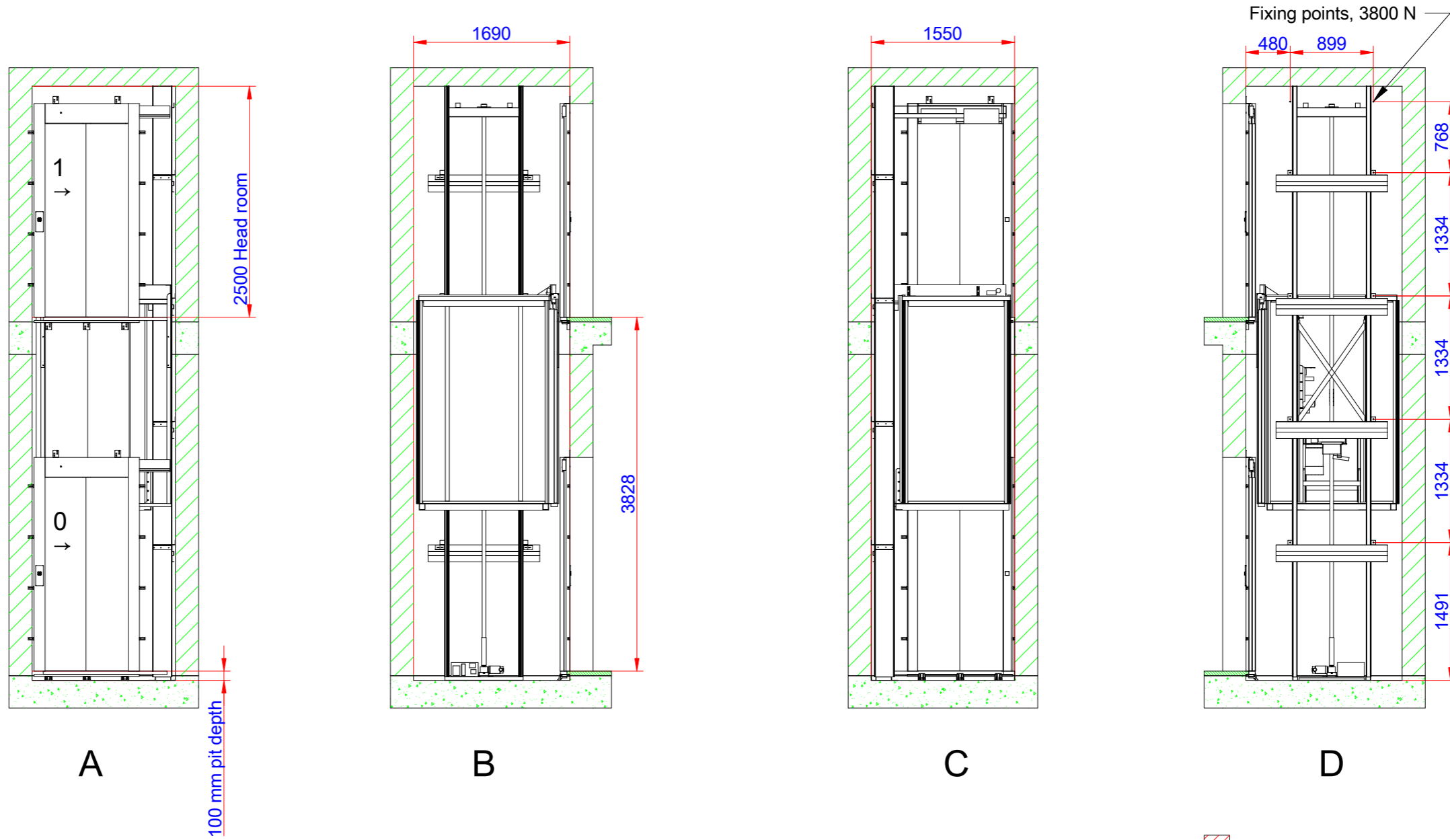

Positioning of machinery:

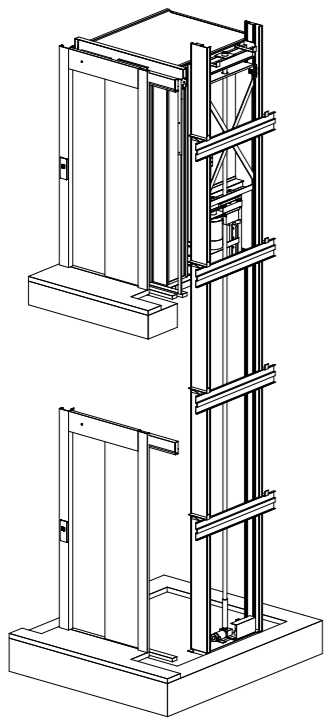
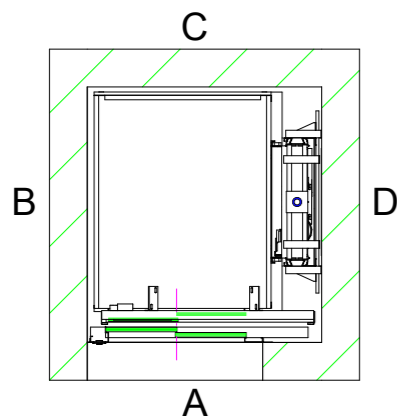

Lift unit installed within a shaft by others

**Specification**  
4 kW Frekv 3x400V 50-60 Hz Soft  
Capacity: 630,00 kg

Approved by  
builder:

European view placement:



EOS ID

Tender no

Order no

Gen. Tolerances

SS-ISO 27681-1 m

**Principal drawing**  
C1-Futura - 1100\*1400  
Lift overview

Date

sheet

1 of 6

Scale:

A3, 1:1

# Cutout sizes for shaft and doors

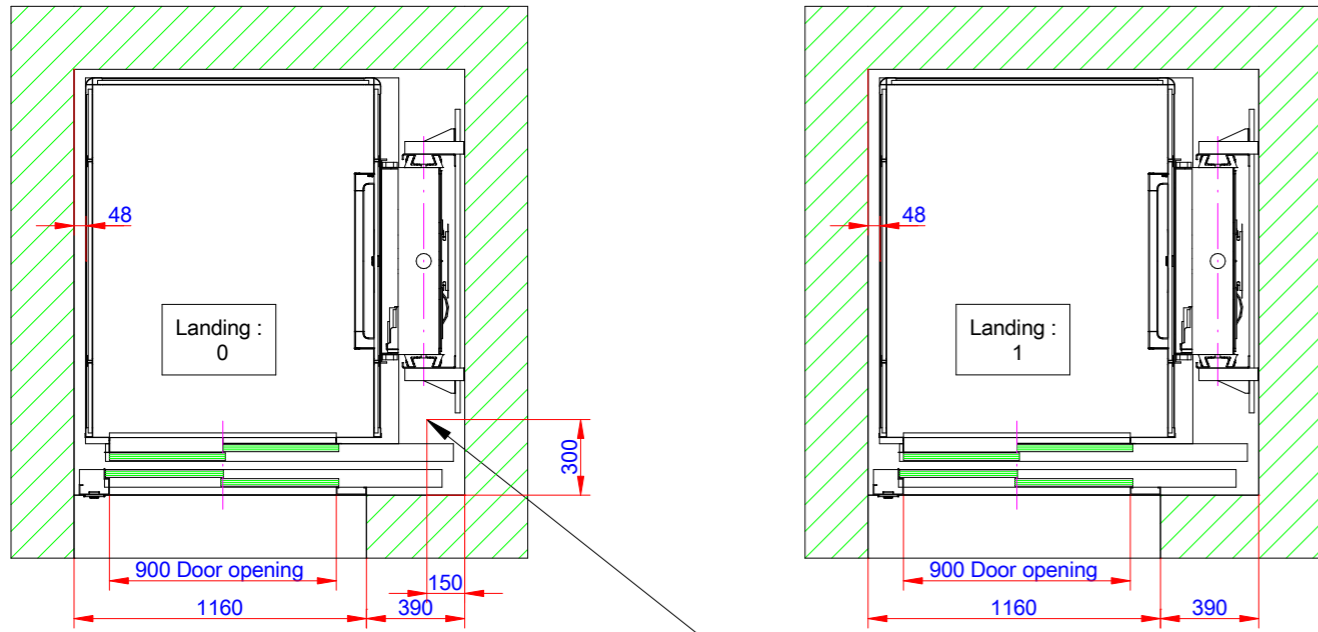

Power supply & telephone cable connection point

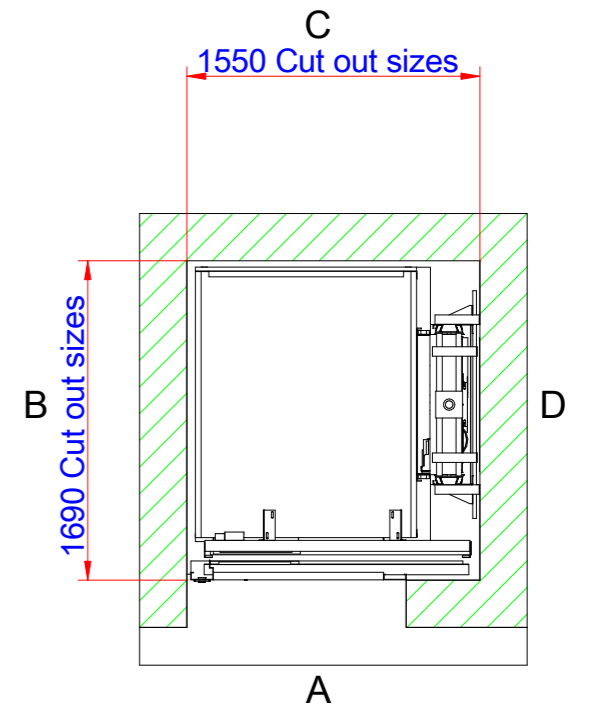

100 mm pit depth + 10 mm, - 0 mm. Bottom surface must be flat

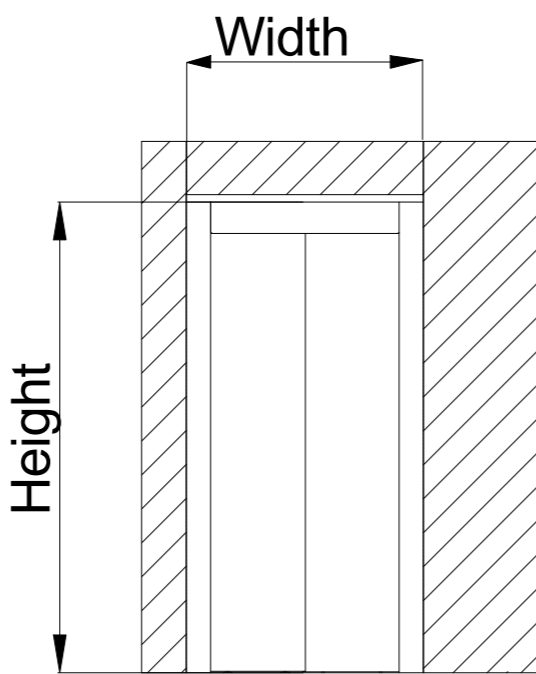
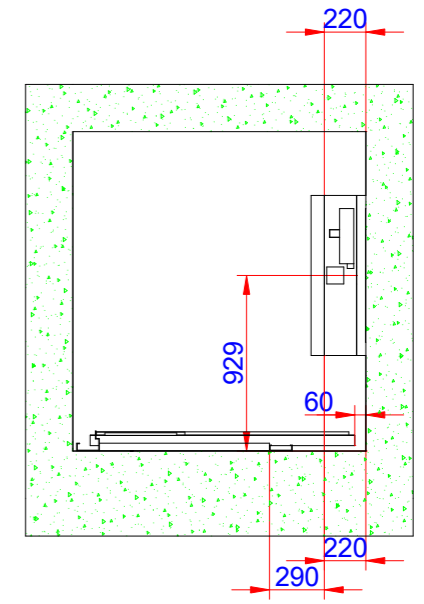

Door cut out

Door front cutout sizes			
Landing	Door type	Width	Height
A 0	CS0	1160	2300
A 1	CS0	1160	2300

Approved by builder:

\_\_\_\_\_

European view placement:





EOS ID  
Tender no  
Order no  
Gen. Tolerances  
SS-ISO 27681-1 m

Principal drawing  
C1-Futura - 1100\*1400  
Cut out sizes  
Date  
sheet 2 of 6  
Scale: A3, 1:1

# Loads and forces in pit and on fixing points

Loads sustained by shaft and platform and fixing points bottom frame

 Mast load: 61,26 kN/m<sup>2</sup>  
 Mast force: 13,17 kN  
 Weight on mast area: 1317

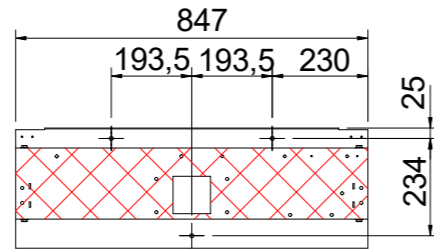

Scale: 1:20

# Fixing points guiderail

Forces:  
Fixing points shaft F: 3800 N

Recommended positioning of fixing points, general view

A ( 1:5 )

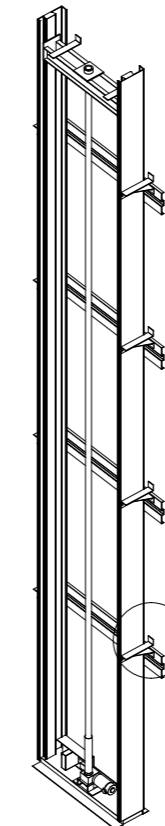

Scale: 1:50

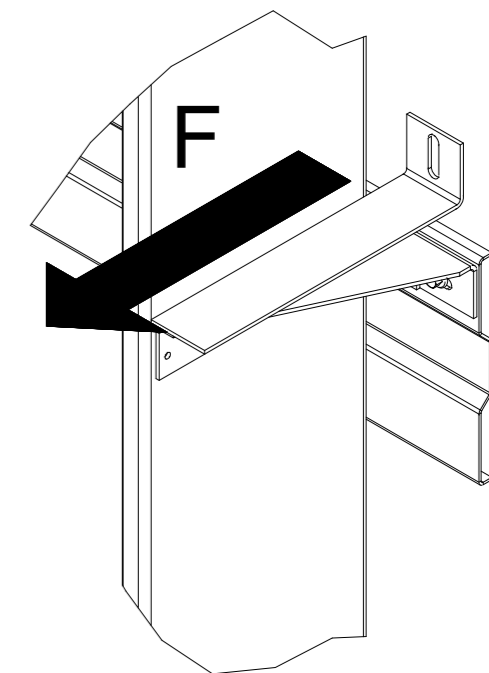

# Fixing points Shaft Doors

B ( 1:10 )

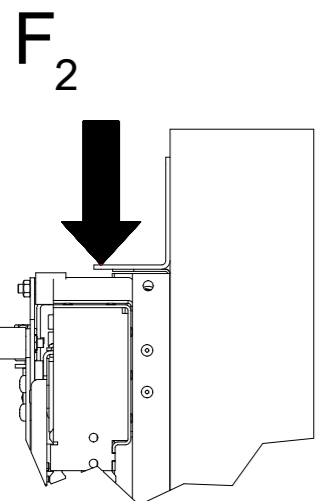

Landing door fixing points. Number of fixing points: 5  
Fixing points landing door F<sub>2</sub>: 1400 N

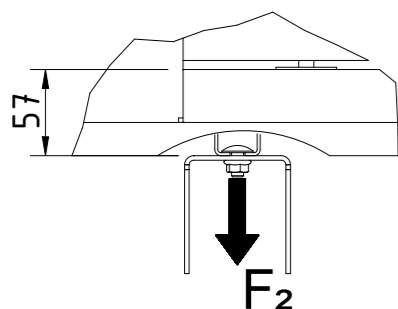

D ( 1:10 )

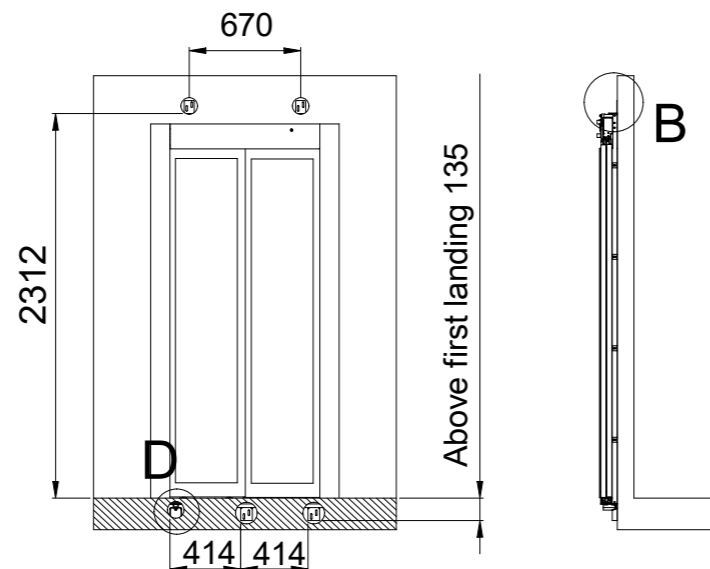

Above first landing 135

Approved by  
builder:

European view placement:



EOS ID

Tender no

Order no

Gen. Tolerances

SS-ISO 27681-1 m

Principal drawing  
C1-Futura - 1100\*1400  
Loads and forces

Date

sheet

3 of 6

Scale:

A3, 1:1

Information for landing 0 and door(s) on landing

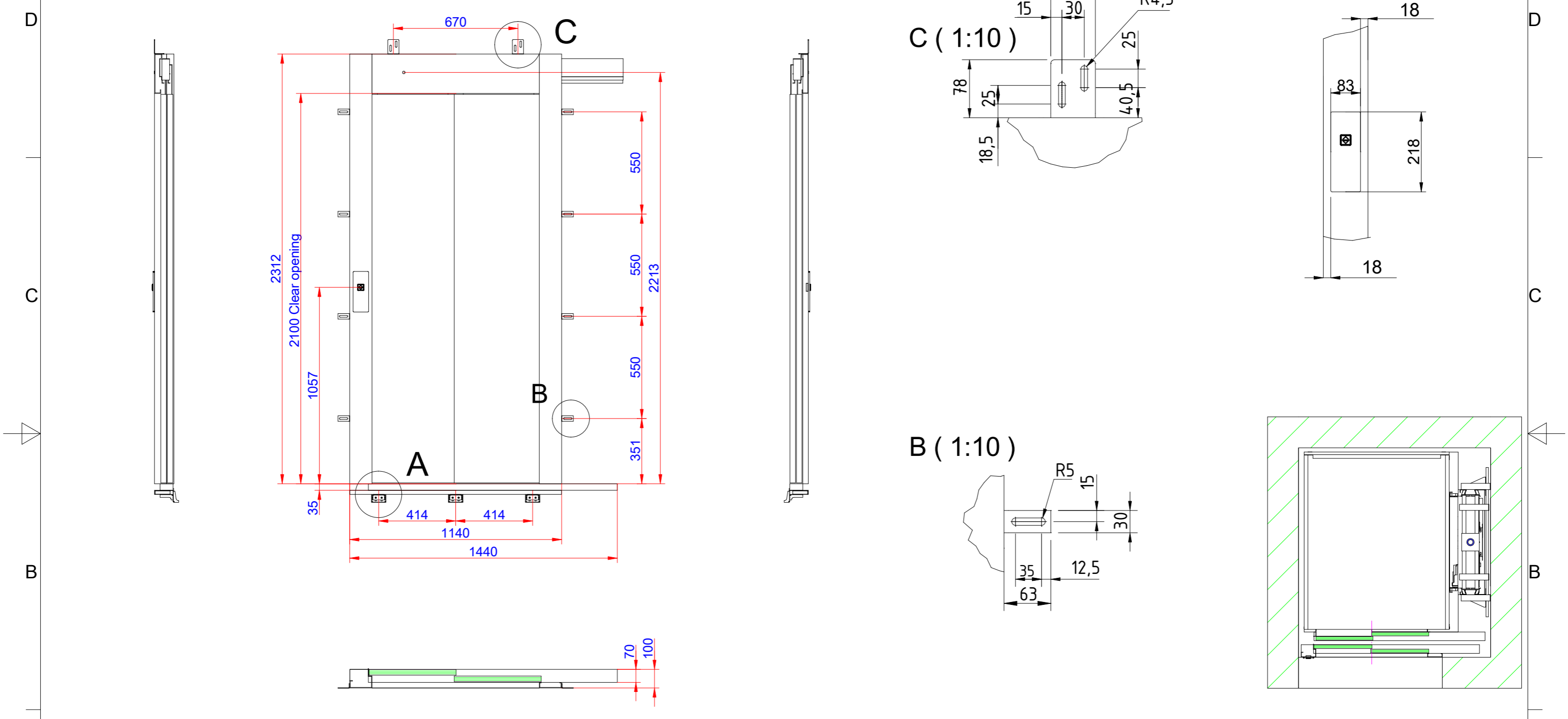

Note for Detail A! When installation is performed inside a pit that is lower than 200 mm, a small bracket must be used fitted under the threshold. This bracket is supplied with the lift.

A ( 1:10 )

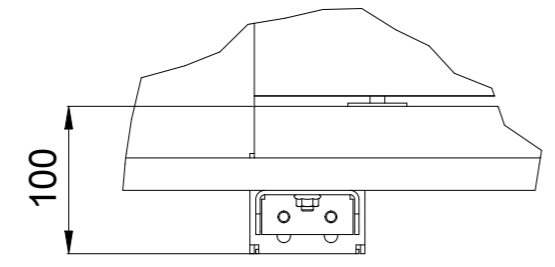

B ( 1:10 )

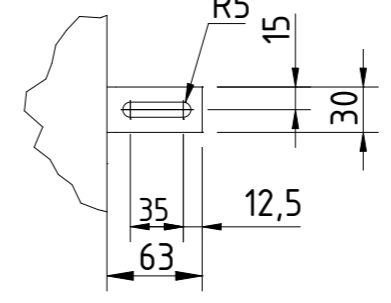

C ( 1:10 )

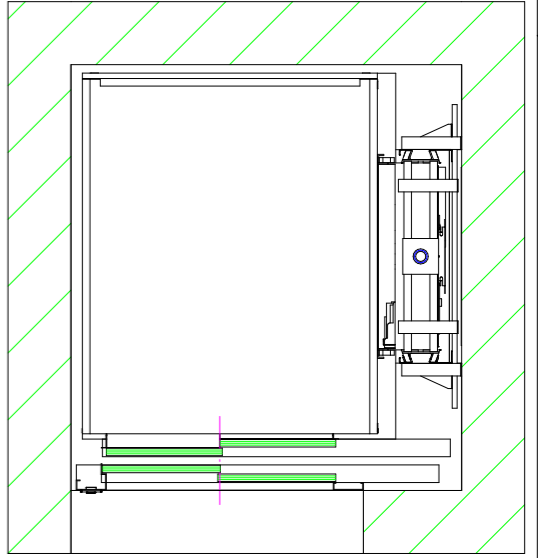
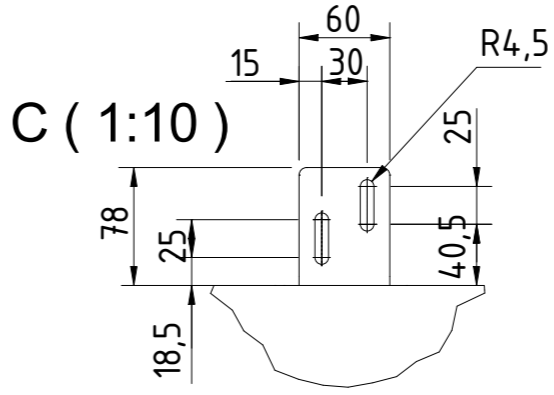

Approved by builder:  
\_\_\_\_\_

European view placement:



EOS ID  
Tender no  
Order no  
Gen. Tolerances  
SS-ISO 27681-1 m

Principal drawing  
C1-Futura - 1100\*1400  
Landing information

Date  
sheet  
4 of 6  
Scale:  
A3, 1:1

Information for landing 1 and door(s) on landing

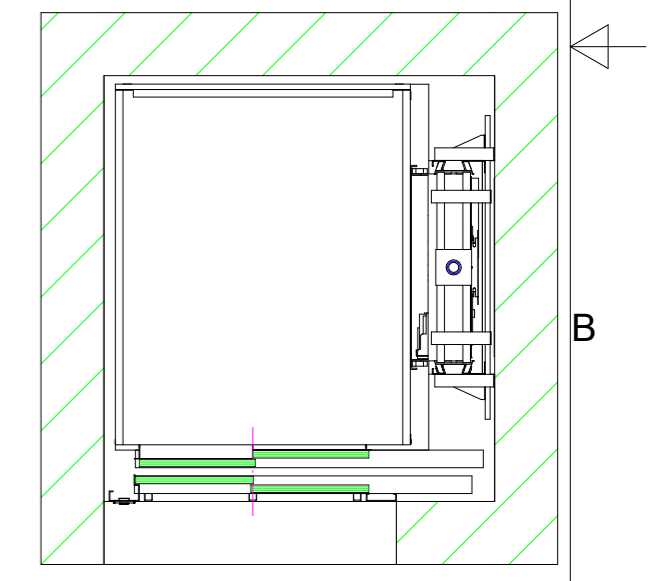
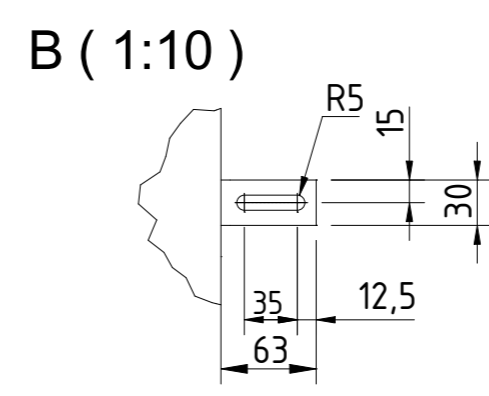
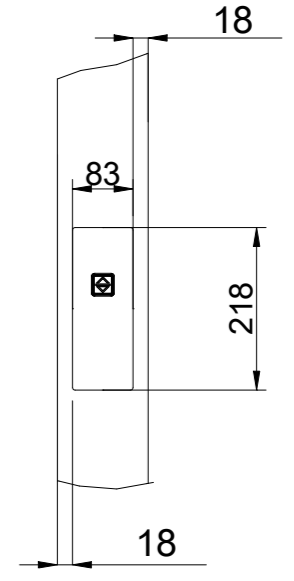
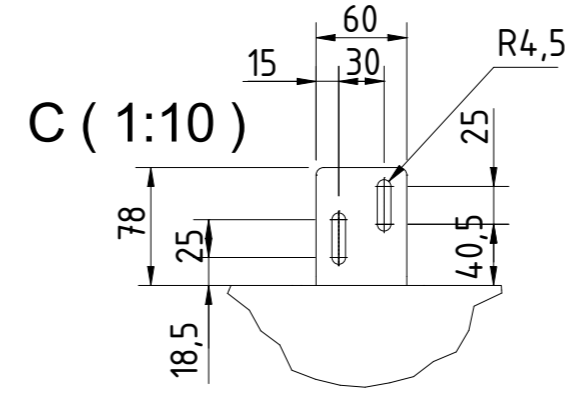
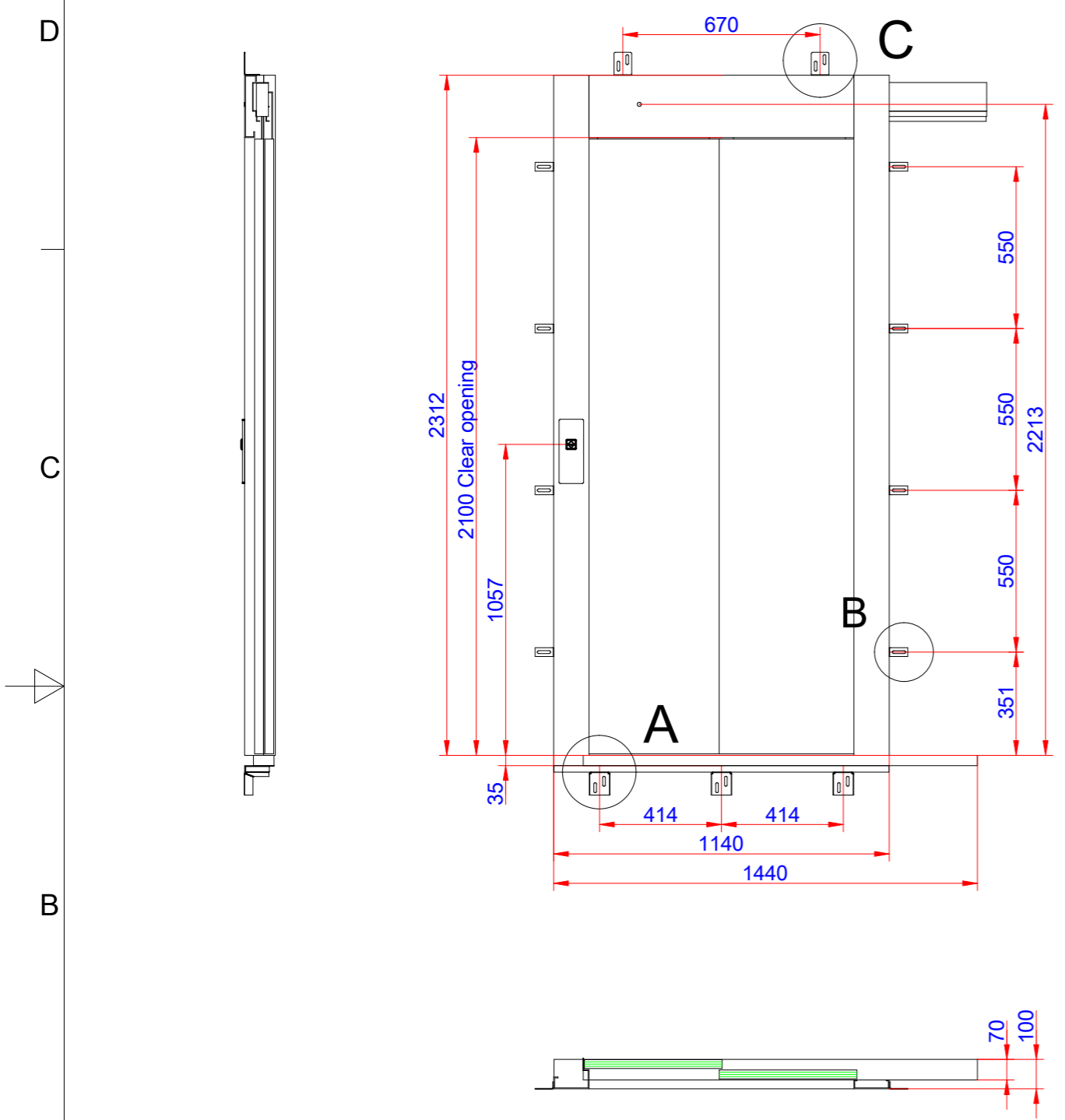

A ( 1:10 )

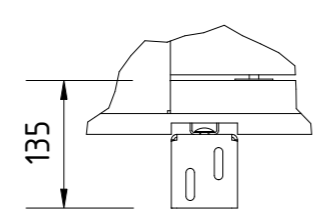

Approved by  
builder:  
\_\_\_\_\_

European view placement:



EOS ID		Principal drawing C1-Futura - 1100*1400 Landing information	
Tender no			
Order no			
Gen. Tolerances	Date	sheet	Scale:
SS-ISO 27681-1 m		5 of 6	A3, 1:1

Cabin layout

E-E ( 1:30 )

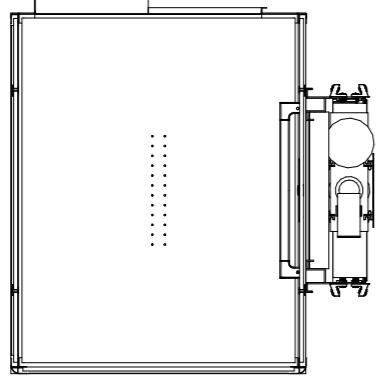

Button layout

A ( 1:10 )

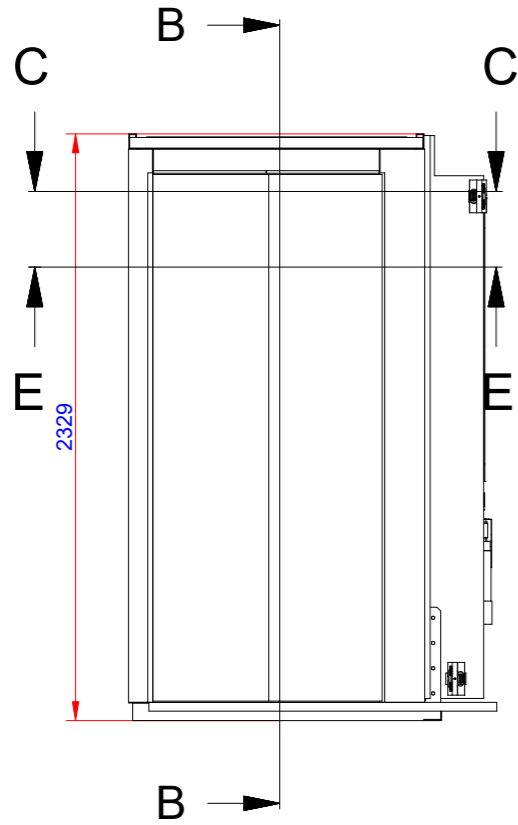
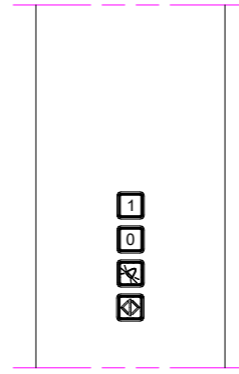

B-B ( 1:30 )

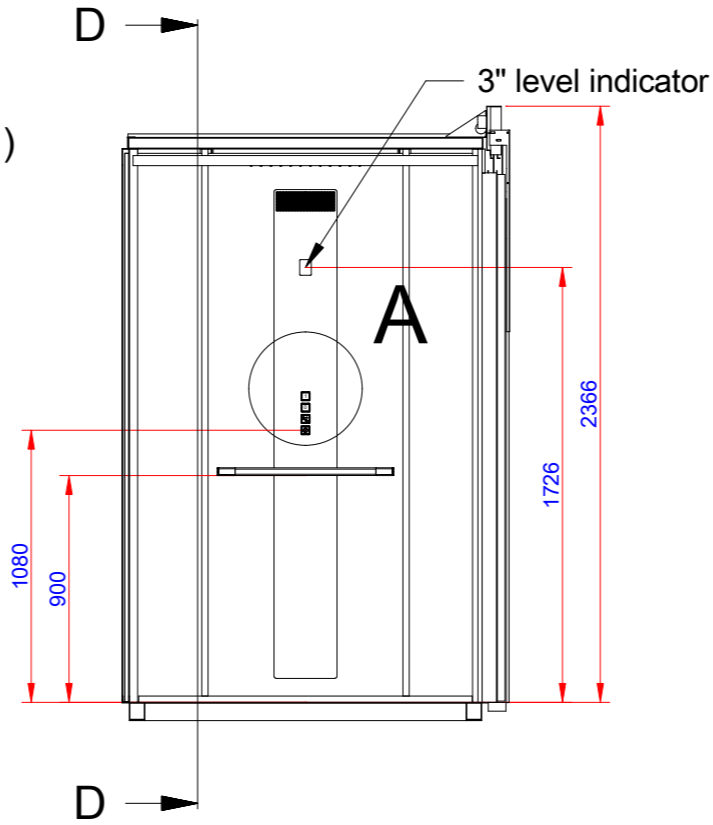

D-D ( 1:30 )

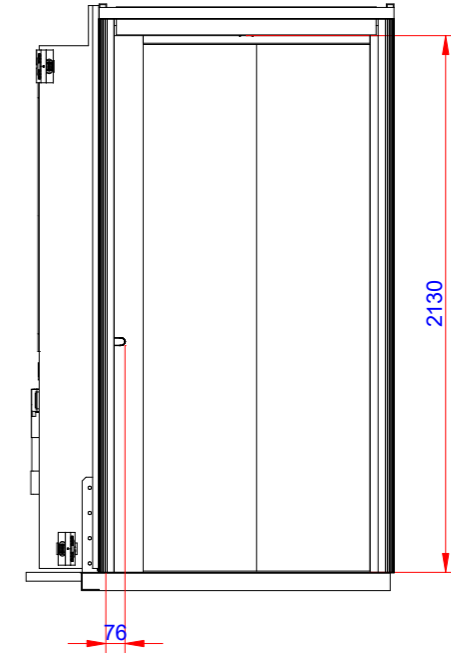

Cabin dimensions  
C-C ( 1:30 )

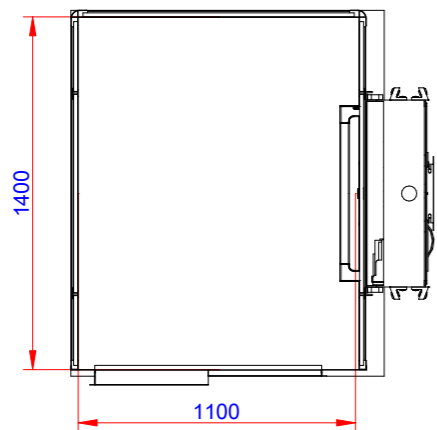

Approved by  
builder:

European view placement:



EOS ID

Tender no

Order no

Gen. Tolerances  
SS-ISO 27681-1 m

Principal drawing  
C1-Futura - 1100\*1400  
Cabin layout

Date

sheet  
6 of 6

Scale:  
A3, 1:1