

# Lift overview

(Cutout dimension see sheet 2, forces see sheet 3  
detailed installation information, see separate instructions)

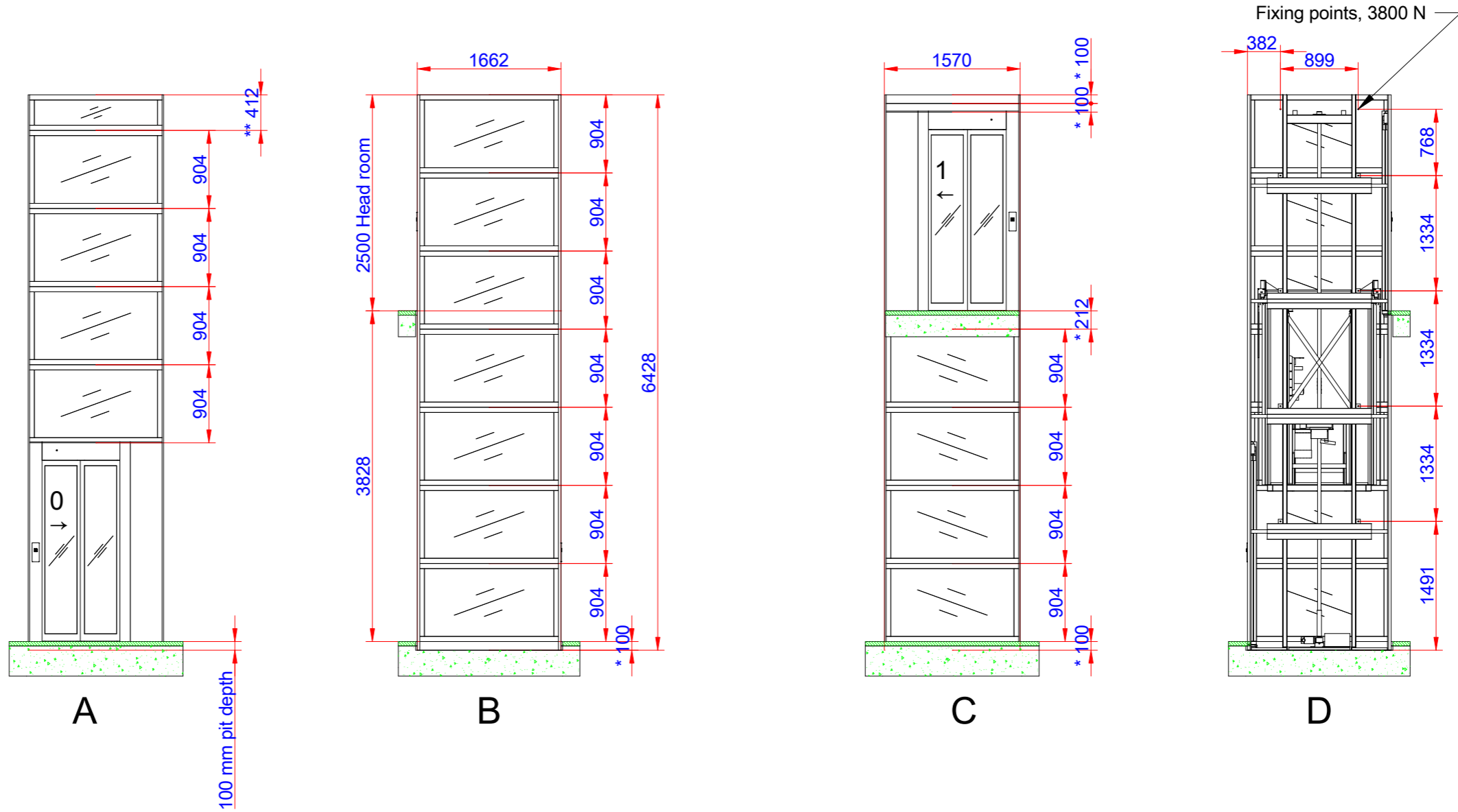

## Positioning of machinery:

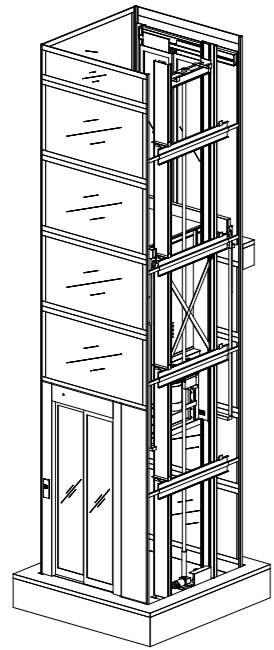
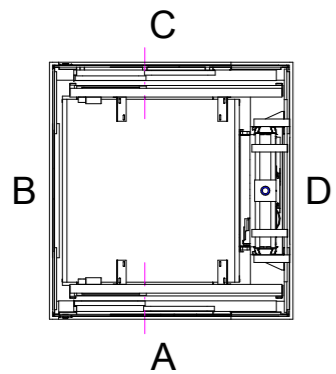

**Specification**  
4 kW Frekv 3x400V 50-60 Hz Soft  
Capacity: 525,00 kg

Approved by  
builder:

European view placement:



Do not use the factory supplied shaft as a fixing structure for other objects

EOS ID	Principal drawing C1-Futura - 1100*1200 Lift overview		
Tender no			
Order no			
Gen. Tolerances	Date	sheet	Scale:
SS-ISO 27681-1 m		1 of 6	A3, 1:60

\*Panel to be adapted on site  
\*\*Customized panel

# Cutout sizes for shaft and doors

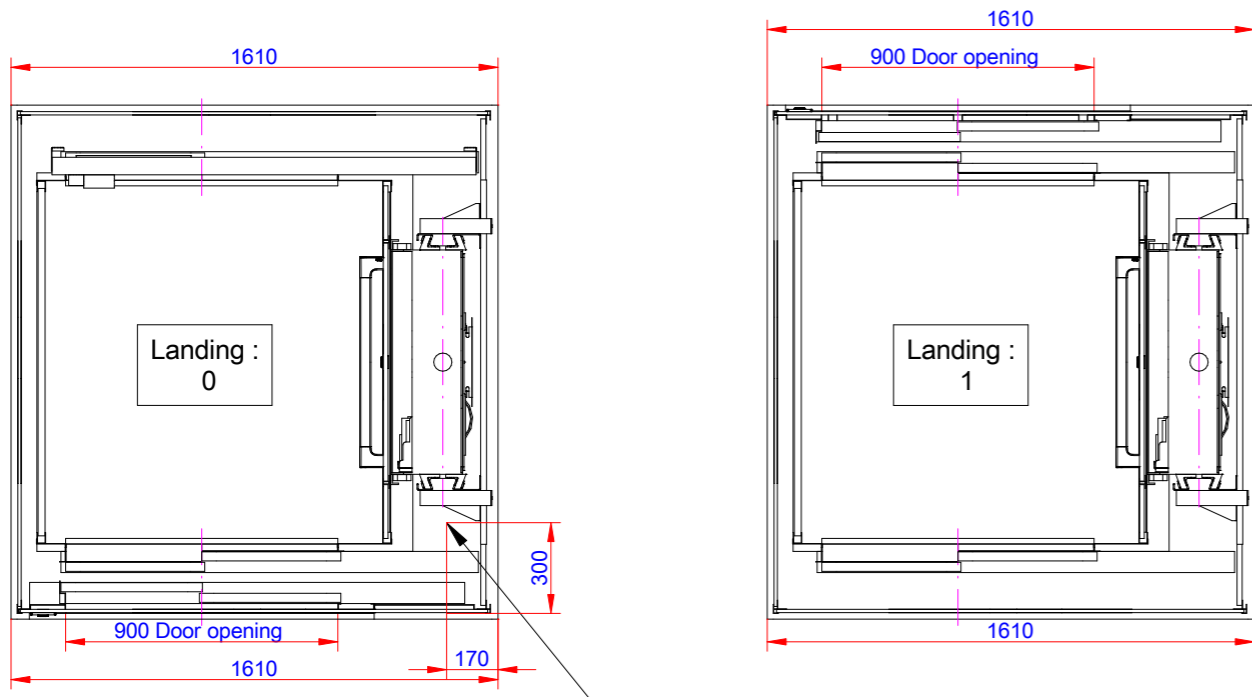

Power supply & telephone cable connection point

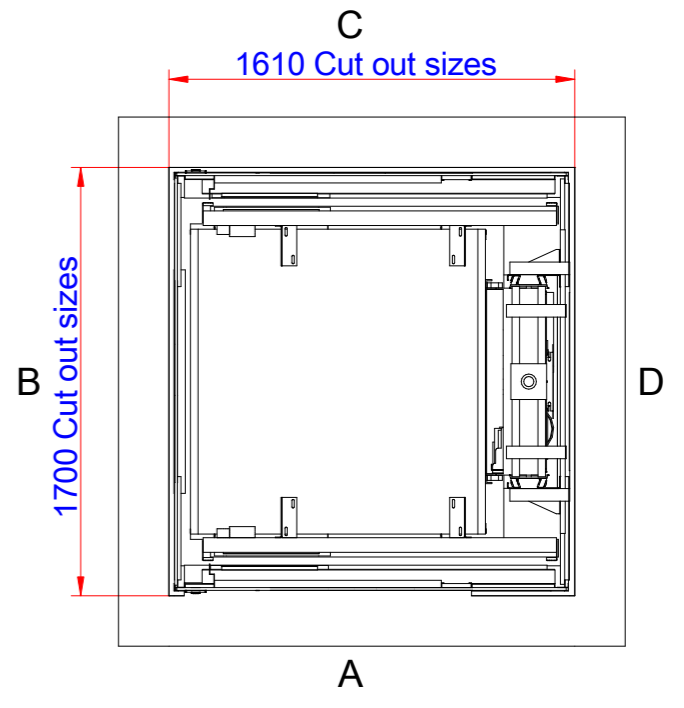

100 mm pit depth + 10 mm, - 0 mm. Bottom surface must be flat

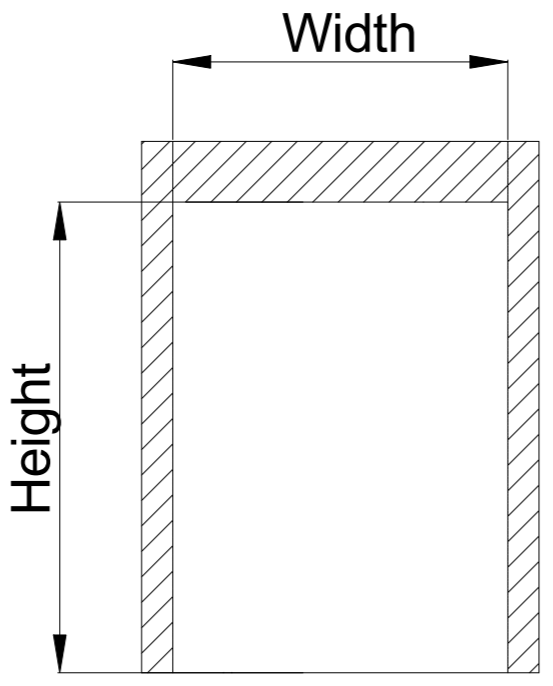

Door cut out

Door front cutout sizes			
Landing	Door type	Width	Height
A 0	CS1	1610	2300
C 1	CS1	1610	2300

Do not use the factory supplied shaft as a fixing structure for other objects

Approved by builder:  
\_\_\_\_\_





EOS ID		Principal drawing C1-Futura - 1100*1200 Cut out sizes	
Tender no			
Order no			
Gen. Tolerances	Date	sheet	Scale:
SS-ISO 27681-1 m		2 of 6	A3, 1:60

European view placement:

# Loads and forces in pit and on fixing points

Loads sustained by shaft and platform and fixing points bottom frame

 Mast load: 56,14 kN/m<sup>2</sup>  
 Mast force: 12,07 kN  
 Weight on mast area: 1207

 L section load 21,34 kN/m<sup>2</sup>  
 L section force: 6,51 kN  
 Weight on L-section area: 651  
 Total weight of the lift equipment  
 (including rated load): 1858 kg

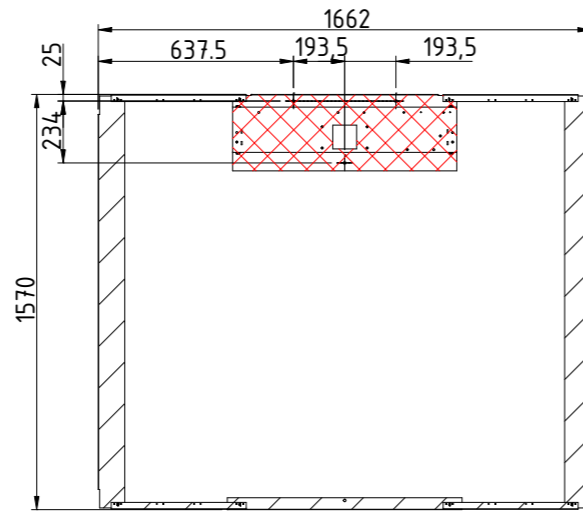

# Fixing points guiderail

Forces:  
Fixing points shaft F: 3800 N

Recommended positioning of fixing points, general view

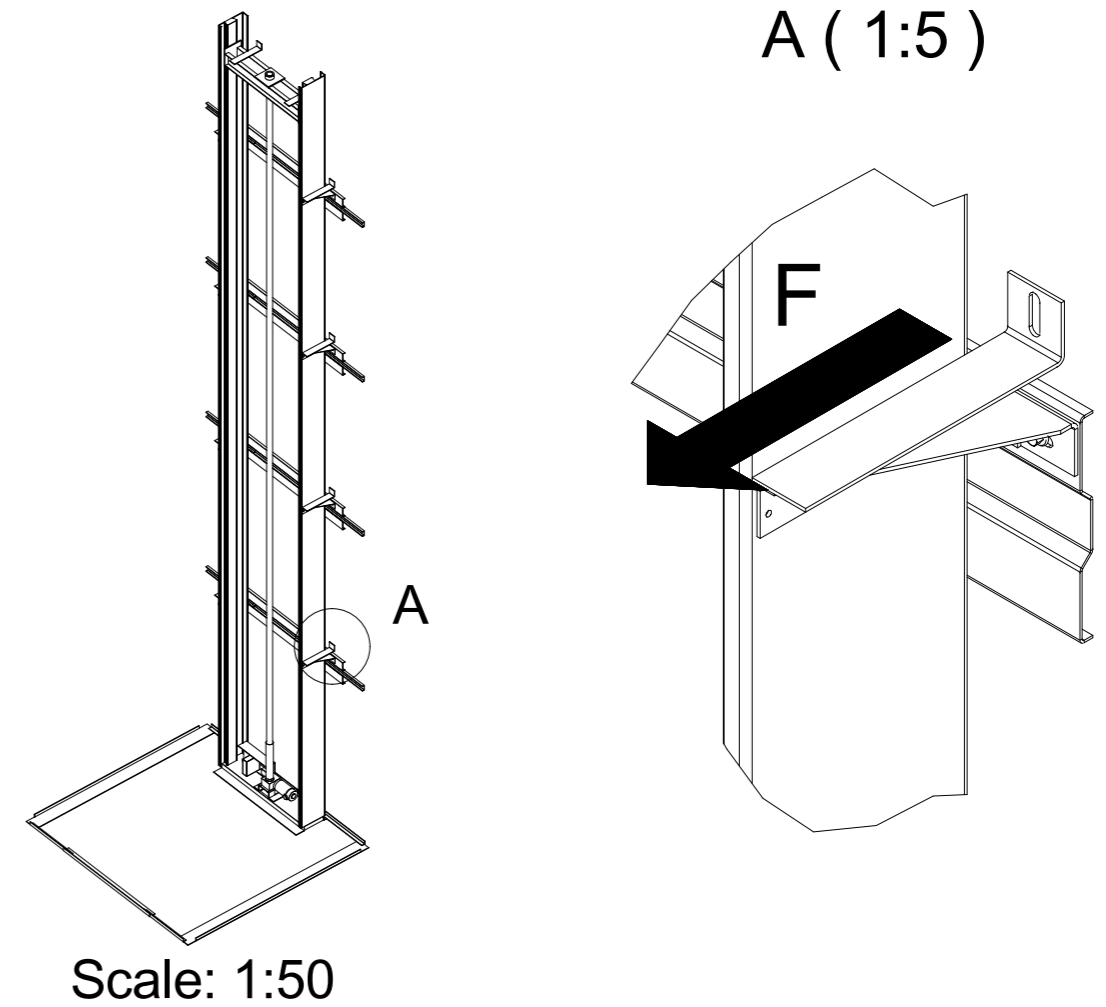

# Fixing points Shaft Doors

B ( 1:10 )

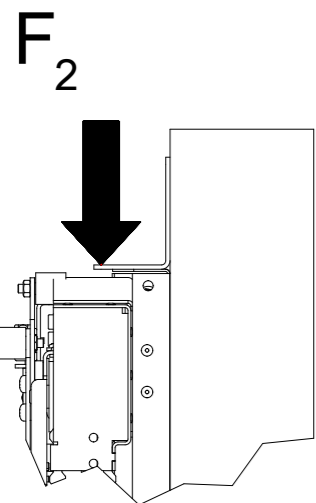

Landing door fixing points. Number of fixing points: 5  
Fixing points landing door F<sub>2</sub>: 1400 N

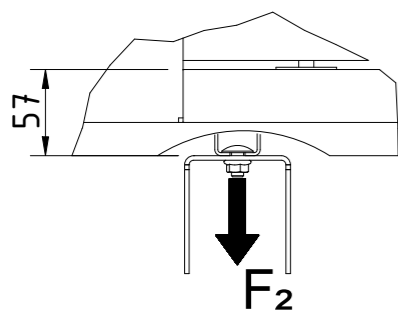

D ( 1:10 )

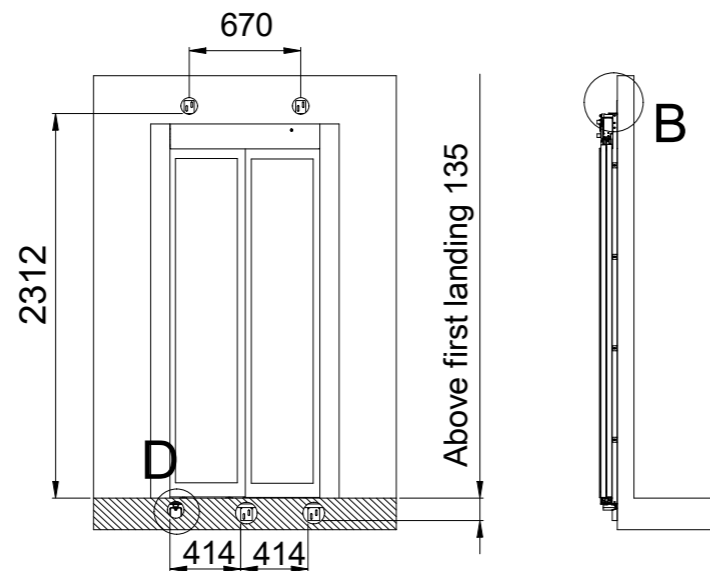

Do not use the factory supplied shaft as a fixing structure for other objects

Approved by builder:

European view placement:



EOS ID	Principal drawing		
Tender no	C1-Futura - 1100*1200		
Order no	Loads and forces		
Gen. Tolerances	Date	sheet	Scale:
SS-ISO 27681-1 m		3 of 6	A3, 1:60

Information for landing 0 and door(s) on landing

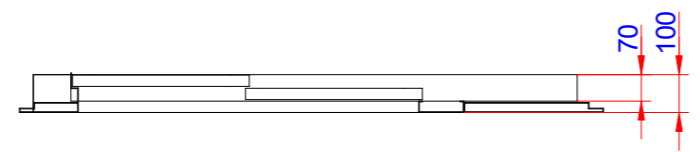
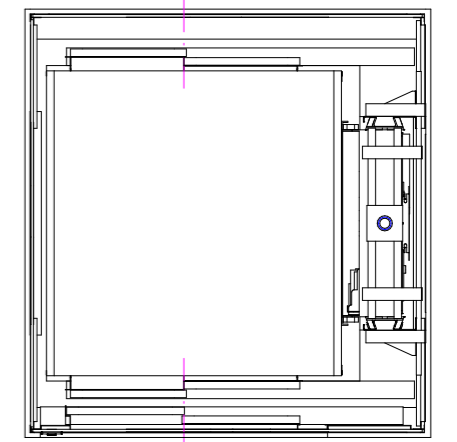
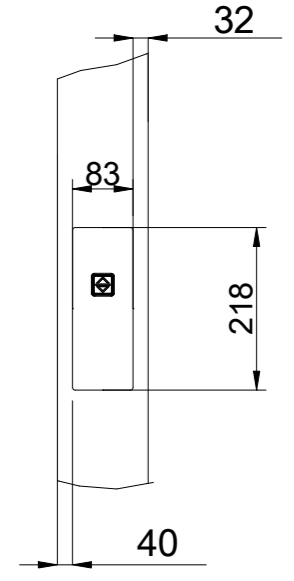
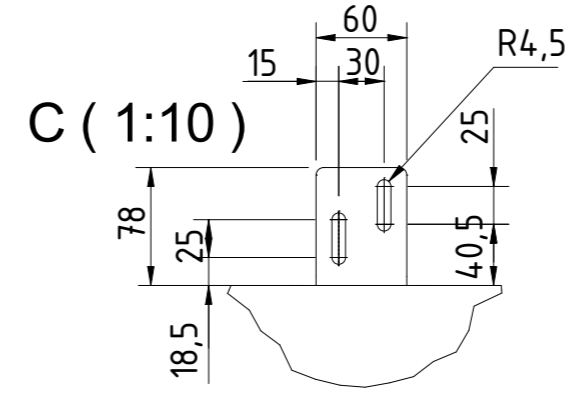
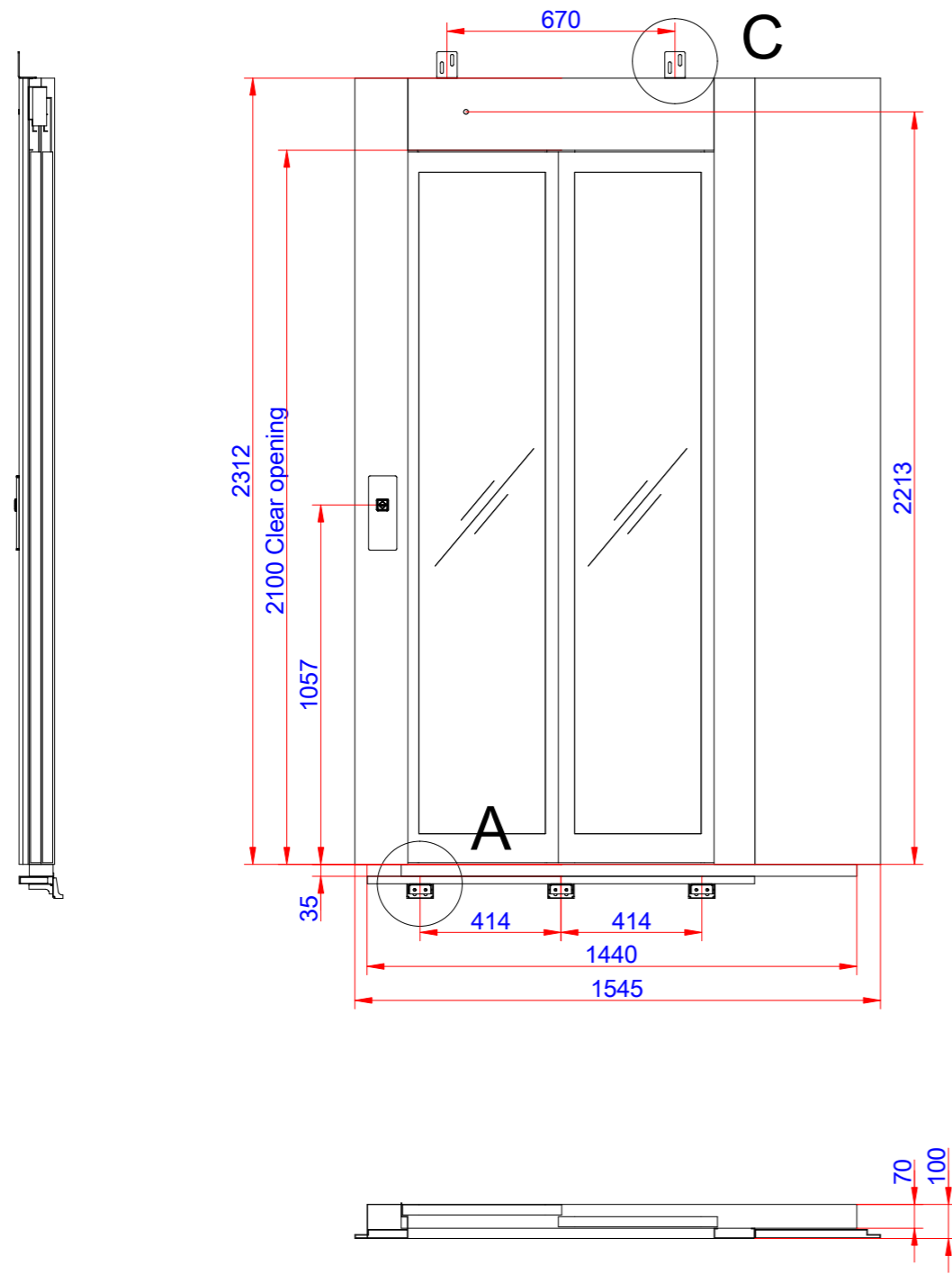

A ( 1:10 )

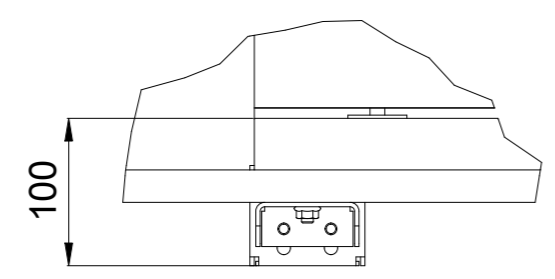

Note for Detail A! When installation is performed inside a pit that is lower than 200 mm, a small bracket must be used fitted under the threshold. This bracket is supplied with the lift.

Do not use the factory supplied shaft as a fixing structure for other objects

Approved by builder:  
\_\_\_\_\_

European view placement:



EOS ID	Principal drawing		
Tender no	C1-Futura - 1100*1200		
Order no	Landing information		
Gen. Tolerances	Date	sheet	Scale:
SS-ISO 27681-1 m		4 of 6	A3, 1:60

Information for landing 1 and door(s) on landing

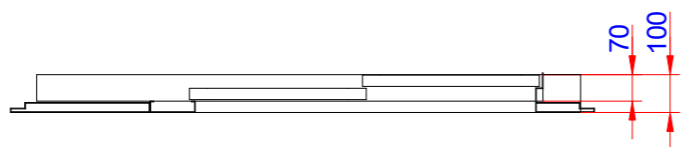
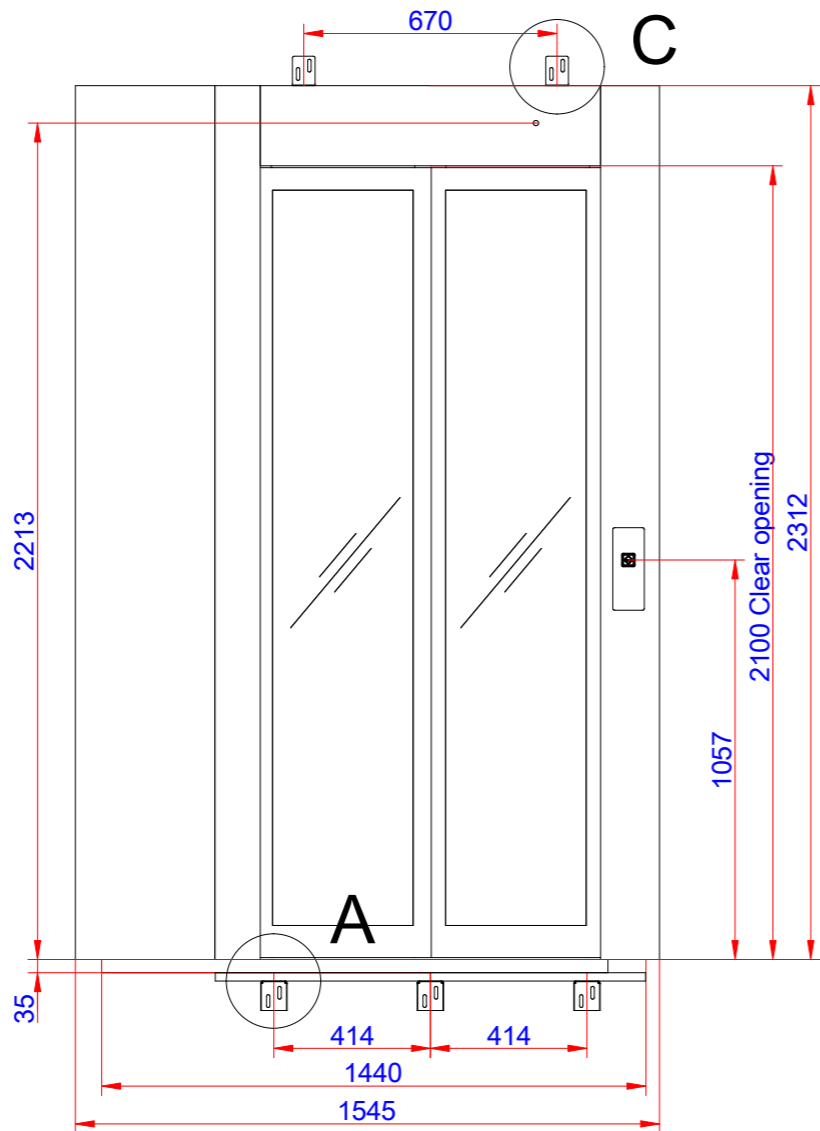
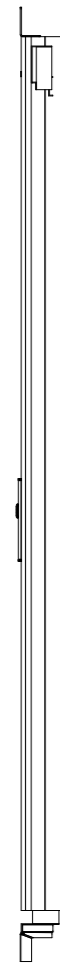

A ( 1:10 )

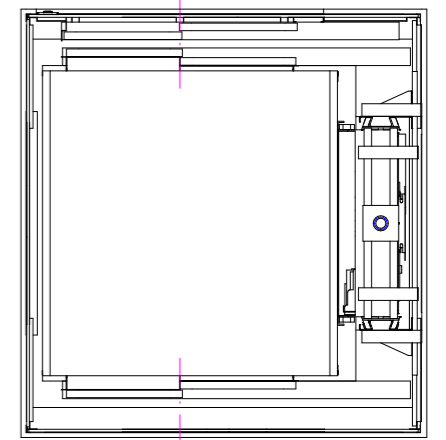
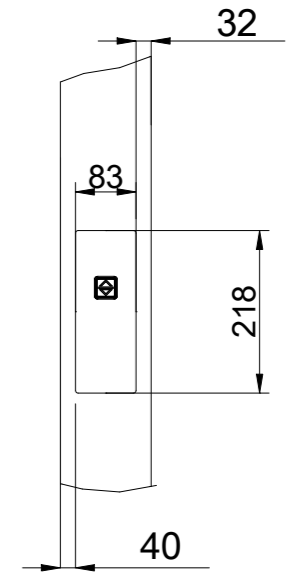
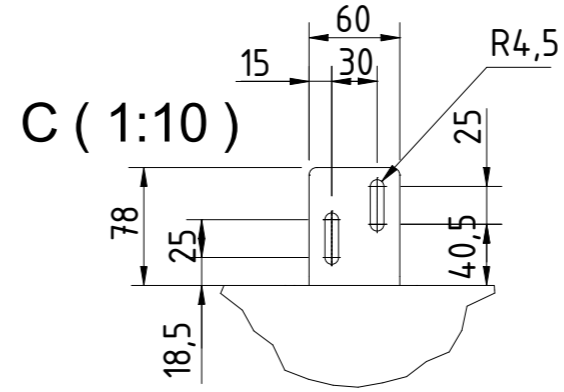
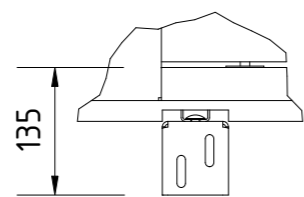

Approved by  
builder:

European view placement:



Do not use the factory supplied shaft as a fixing structure for other objects

EOS ID	Principal drawing		
Tender no	C1-Futura - 1100*1200		
Order no	Landing information		
Gen. Tolerances	Date	sheet	Scale:
SS-ISO 27681-1 m		5 of 6	A3, 1:60

Cabin layout

E-E ( 1:30 )

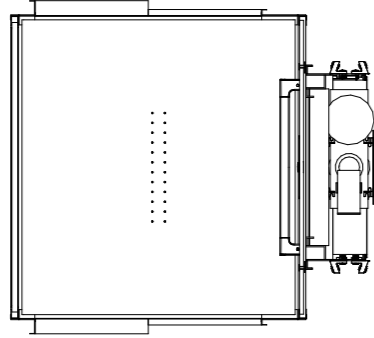

Button layout

A ( 1:10 )

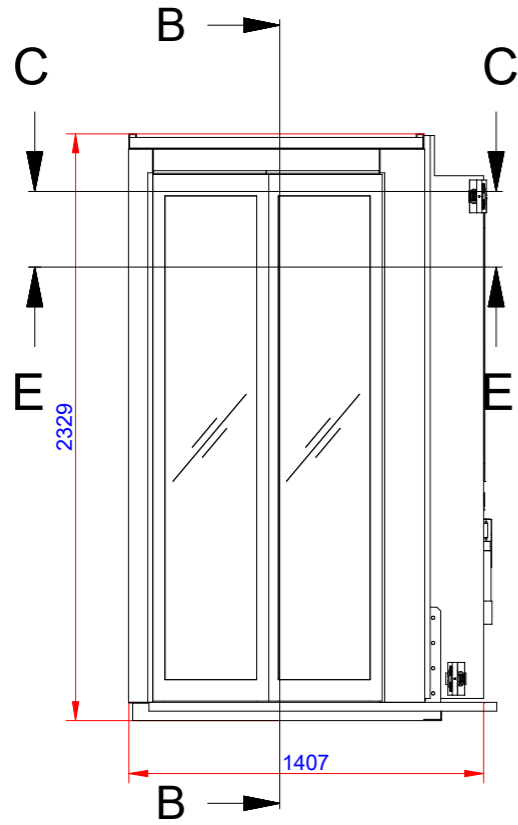
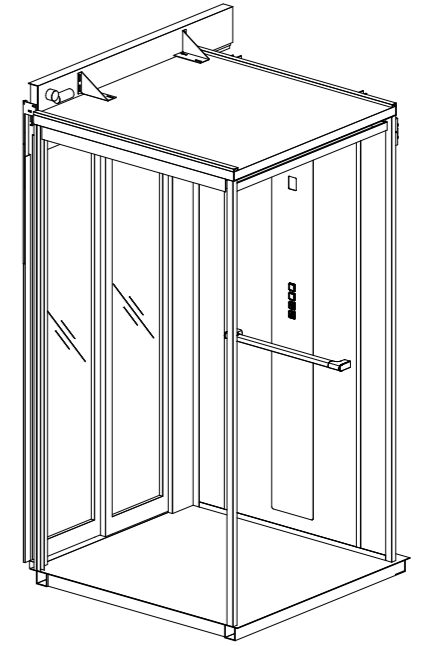
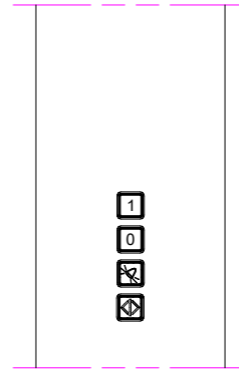

B-B ( 1:30 )

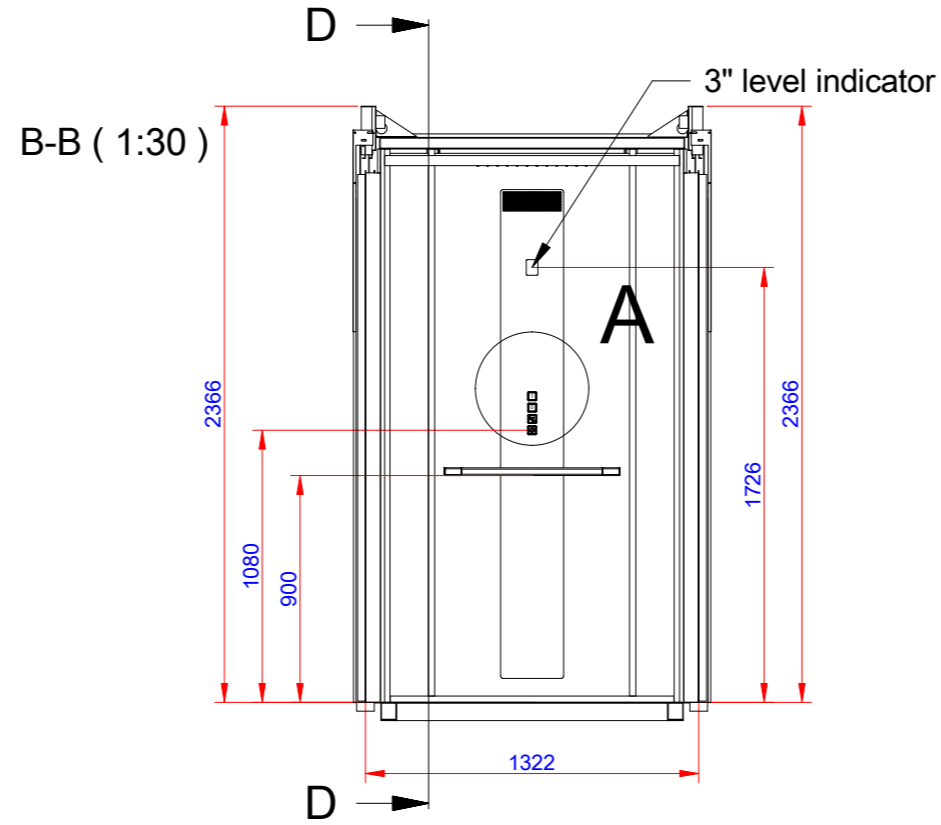

D-D ( 1:30 )

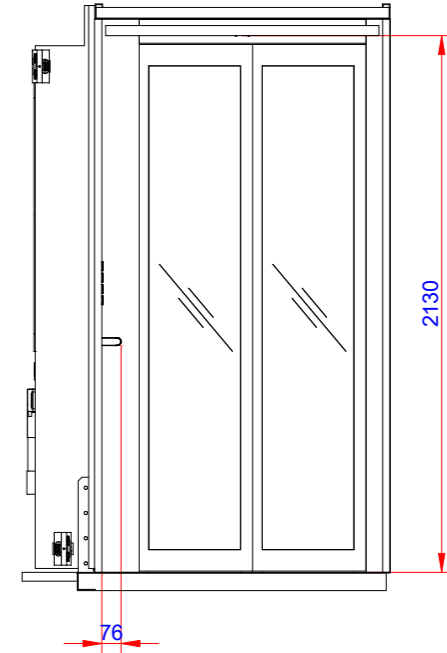

Cabin dimensions  
C-C ( 1:30 )

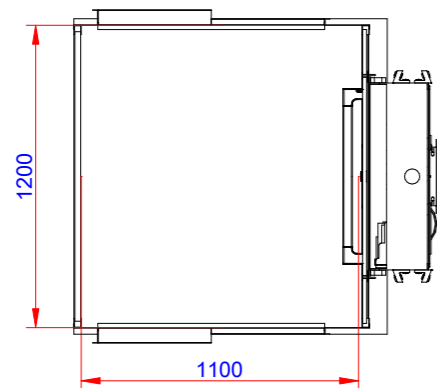

Do not use the factory supplied shaft as a fixing structure for other objects

Approved by  
builder:

European view placement:



EOS ID

Tender no

Order no

Gen. Tolerances

SS-ISO 27681-1 m

Principal drawing  
C1-Futura - 1100\*1200  
Cabin layout

Date

sheet

6 of 6

Scale:

A3, 1:60