

Cutout dimension see sheet
2, forces see sheet 3

*To be adapted on site
**Customized panel

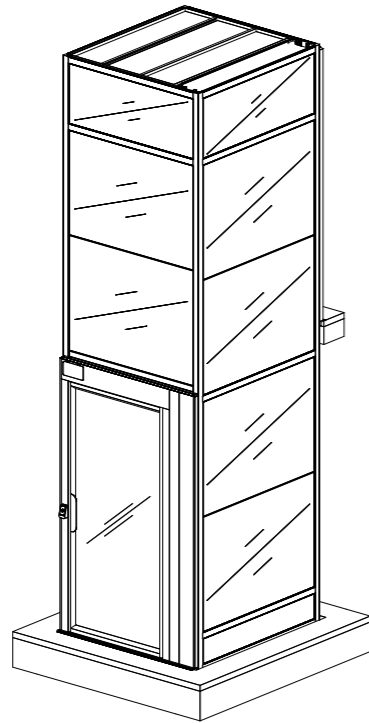

E
Positioning of machinery:

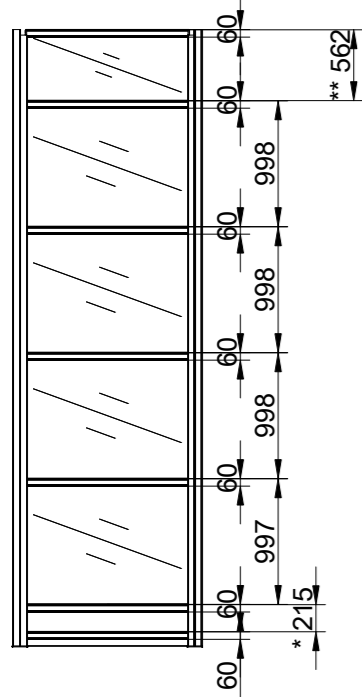
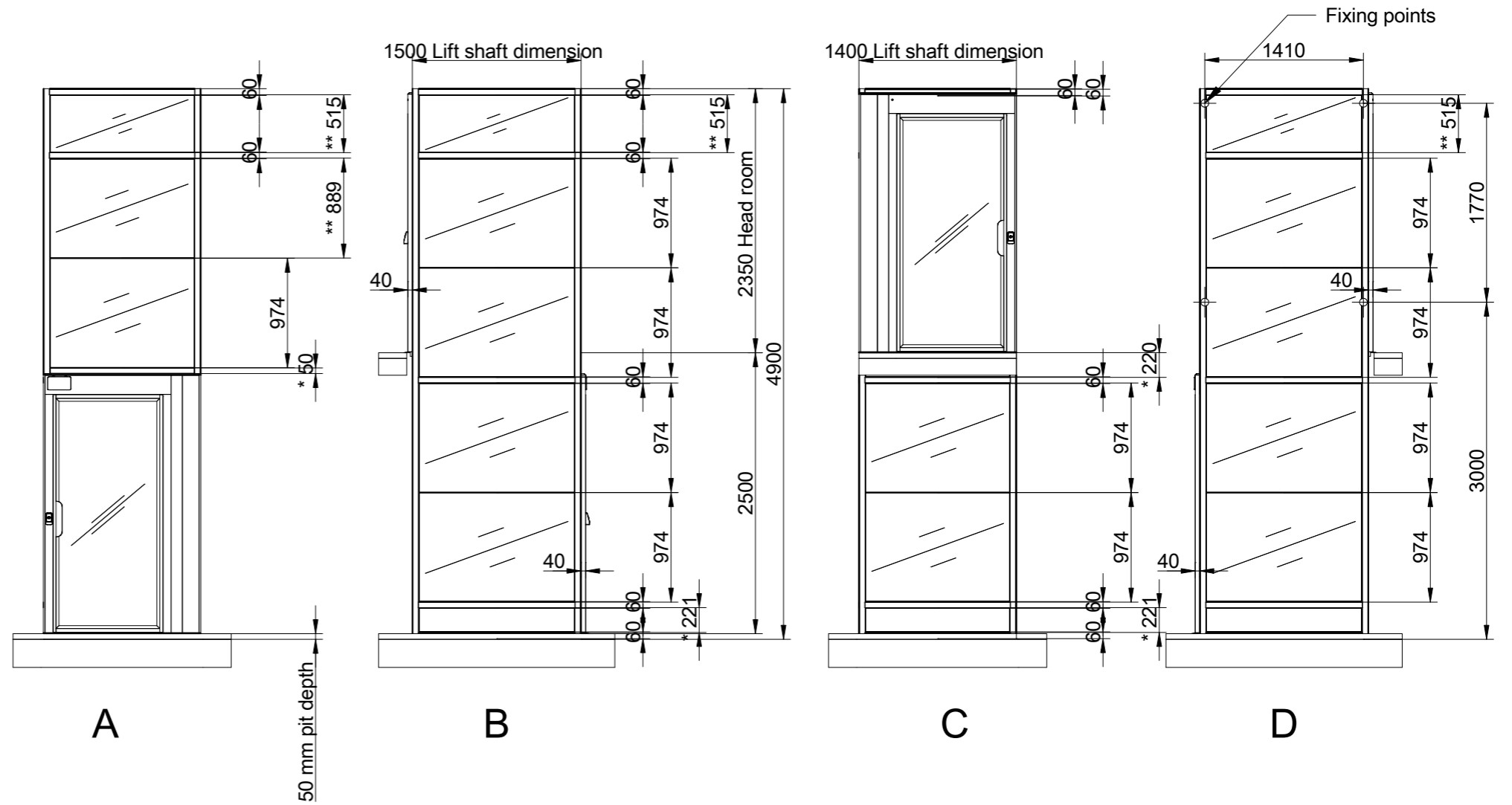
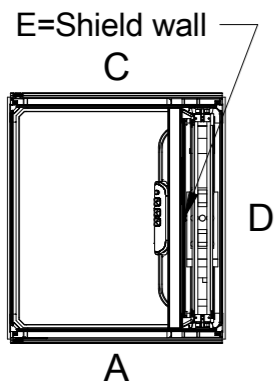

Options
400 kg
Power supply 1x230

Approved by builder:

European view placement:



Tender no
202307101774

Gen. Tolerances
SS-ISO 27681-1 m

Principal drawing

1 - 1025*1450

Shaft drawing

Johanna Aaw Kalea 1025x450

Date
2023-07-10
05:59

sheet
1 of 6

Scale:
A3, 1:50

Shaft cutout sizes

Door front cutout sizes		
Landing	Width	Height
A 0	1440	2315
C 1	1440	2315

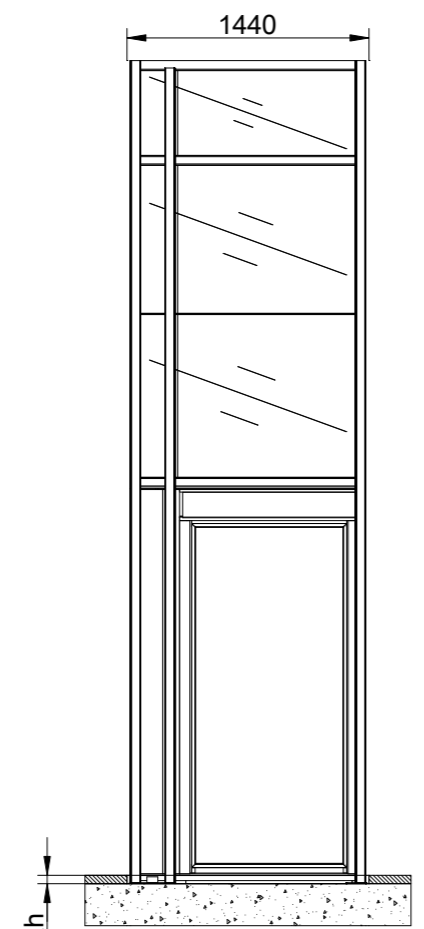
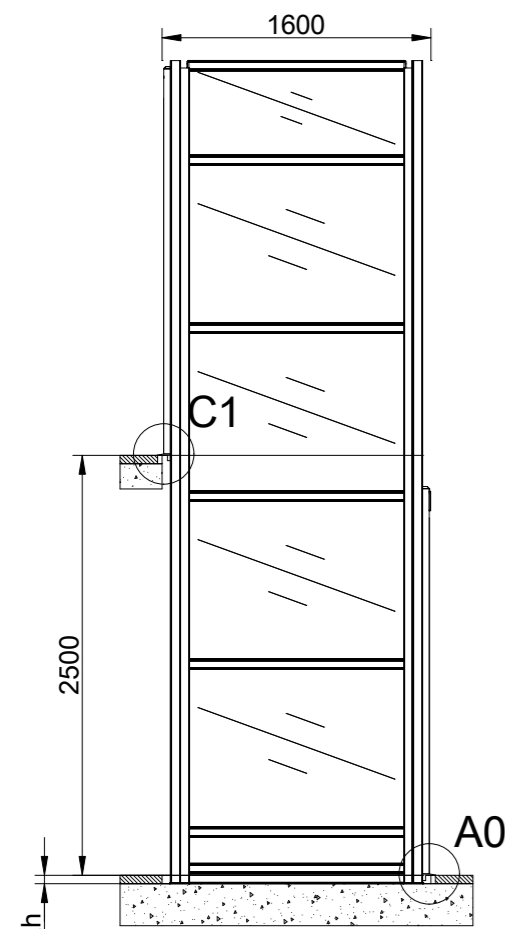
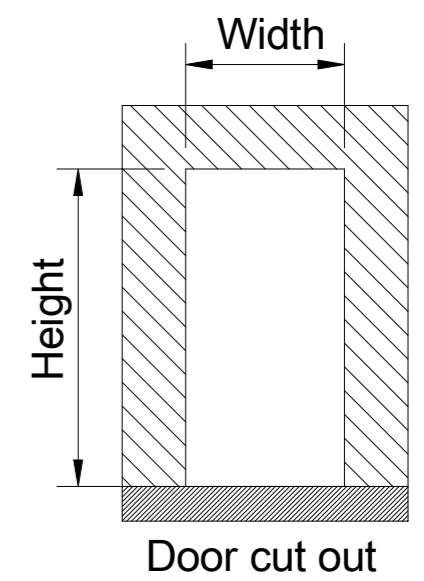

Section E-E

Section G-G

50 mm pit depth + 10 mm, - 0 mm.
Bottom surface must be flat

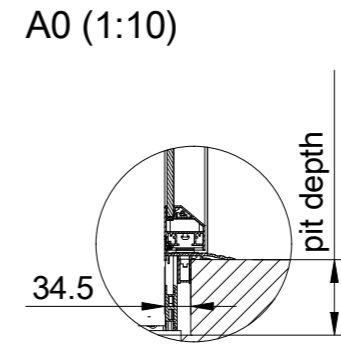
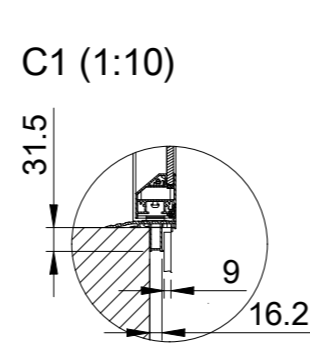
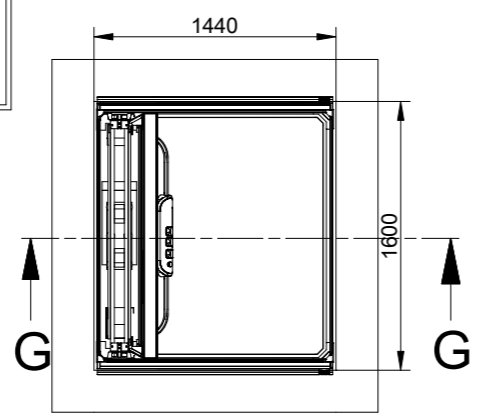
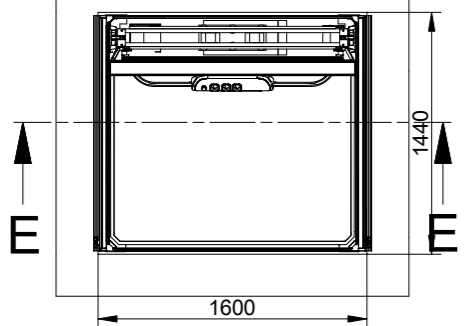

Approved by builder:

European view placement:



Principal drawing			
1 - 1025*1450			
Cut out sizes			
Johanna Aaw Kalea 1025x450			
Gen. Tolerances	Date	sheet	Scale:
SS-ISO 27681-1 m	2023-07-10 05:59	2 of 6	A3, 1:50

6 5 4 3 2 1

Loads sustained by shaft and platform
and fixing points bottom frame

Loads per fixing point:
 $F=3200\text{ N}$ if the distance between the fixing points is 2999 mm or less
 $F=2200\text{ N}$ if the distance between the fixing points is 3000 mm or more



L section force: 3.74 kN
 L section load:
 Weight on L-section
 area: 374 kg



Mast force: 13.62 kN
 Mast load:
 Weight on mast area (including rated load) 1362 kg

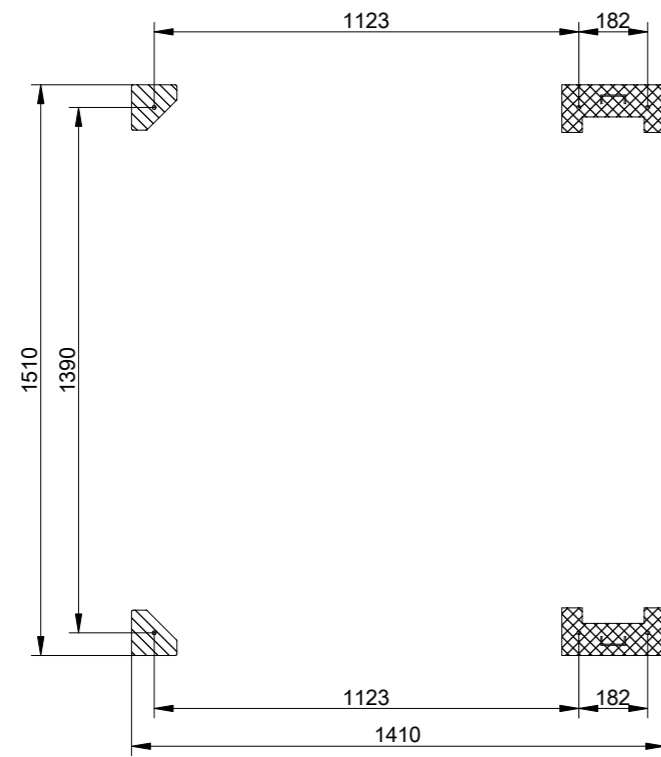

Scale: 1:20

Total weight of the lift equipment (including rated load)
 1736 kg

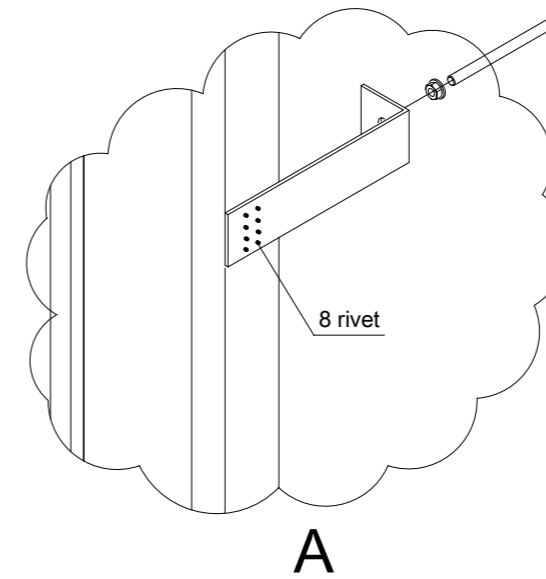
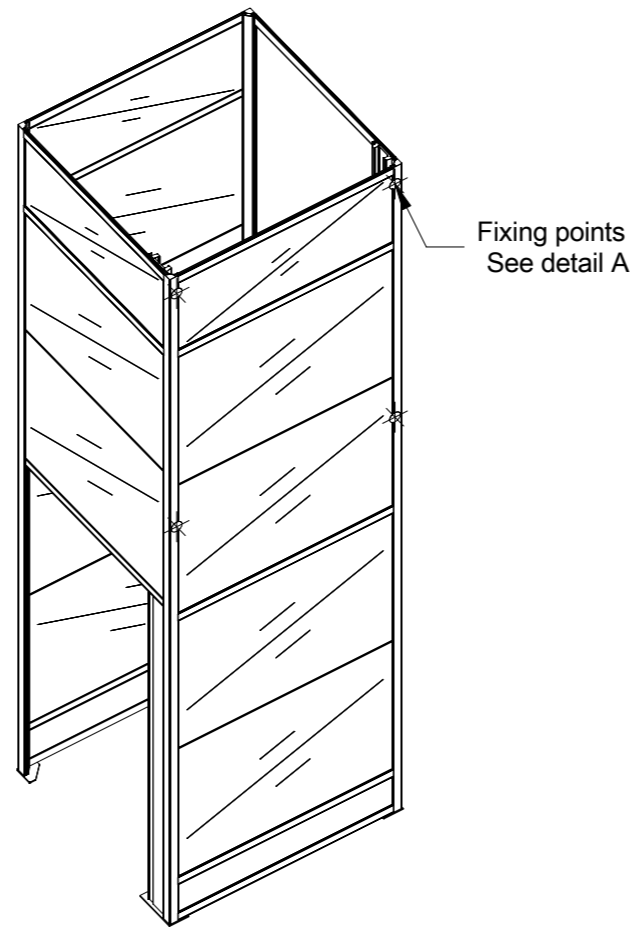

D

C

B

A

D

C

B

A

6 5 4 3 2 1

Approved by builder:

European view placement:



Tender no
 202307101774

Gen. Tolerances
 SS-ISO 27681-1 m

Principal drawing

1 - 1025*1450

Loads and forces

Johanna Aaw Kalea 1025x450

Date
 2023-07-10
 05:59

sheet
 3 of 6

Scale:
 A3, 1:50

Landing 0 and door front information
Scale: 1:20

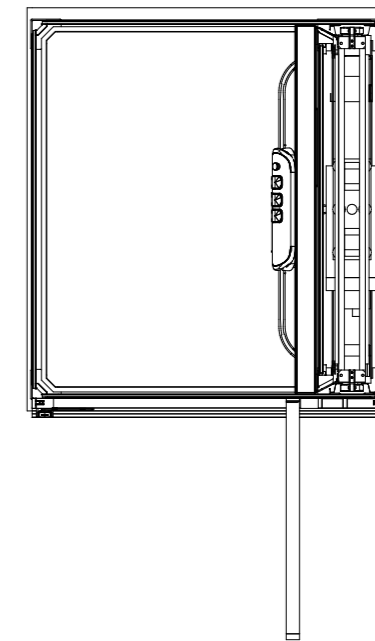
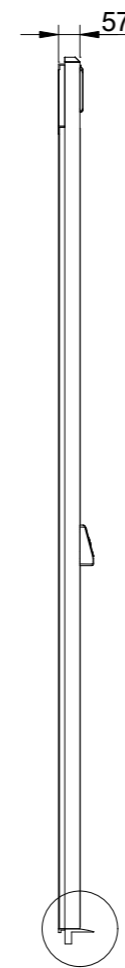
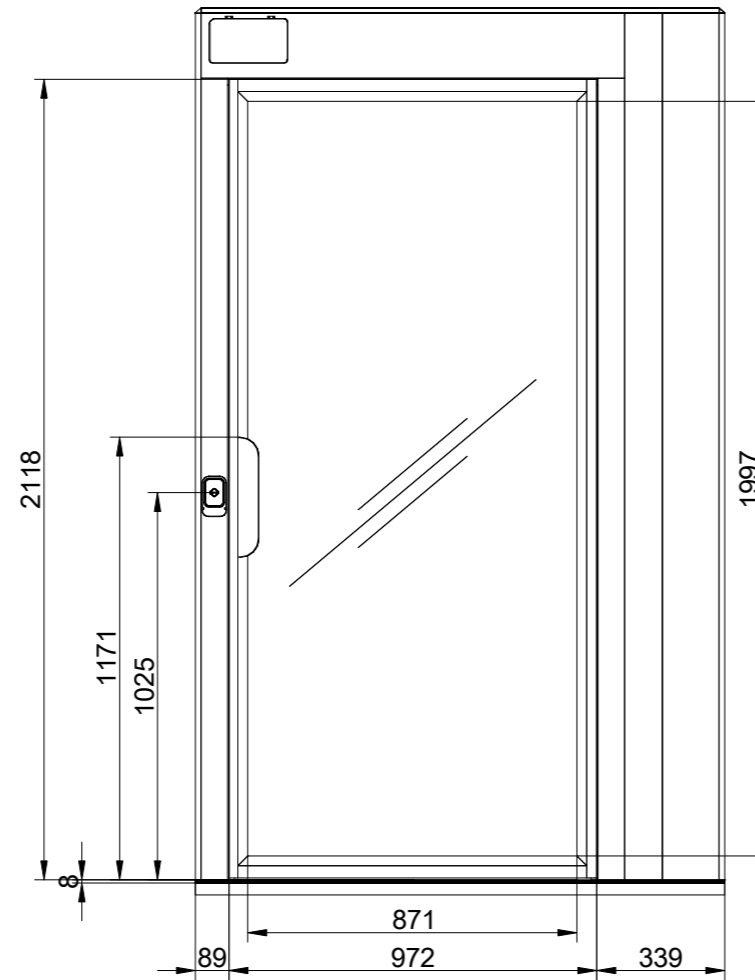
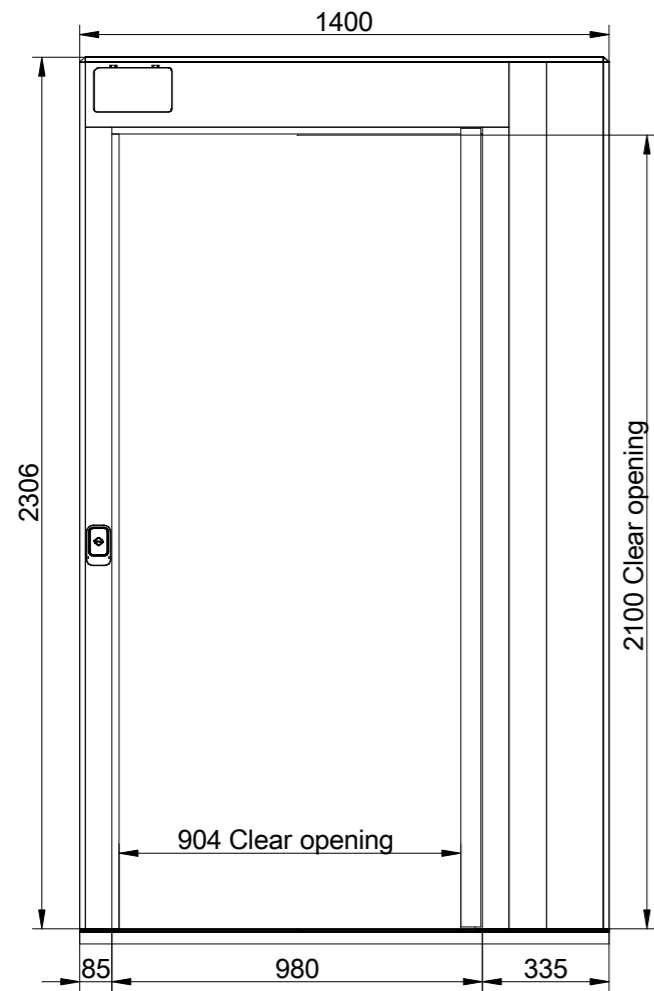

Scale: 1:30

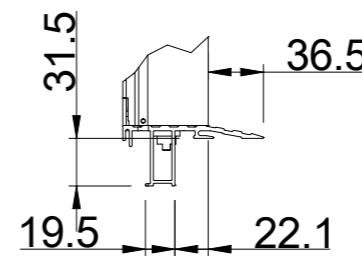

A (1:5)

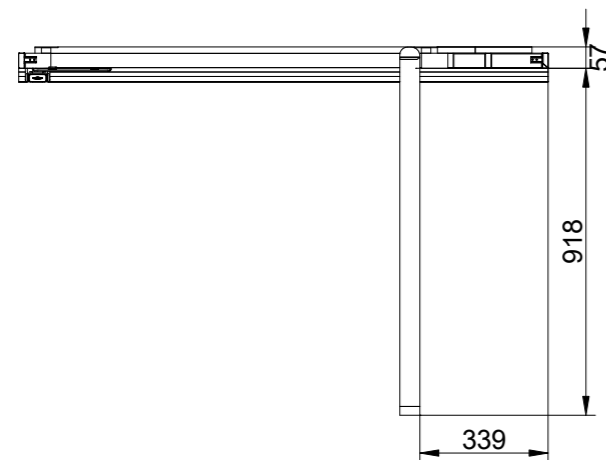

Landing	Door type
0	Panoramic Plus
1	Panoramic Plus

Approved by builder:

European view placement:



Tender no
202307101774

Gen. Tolerances
SS-ISO 27681-1 m

Principal drawing

1 - 1025*1450

Cut out sizes

Johanna Aaw Kalea 1025x450

Date
2023-07-10
05:59

sheet
4 of 6

Scale:
A3, 1:50

Landing 1 and door front information
Scale: 1:20

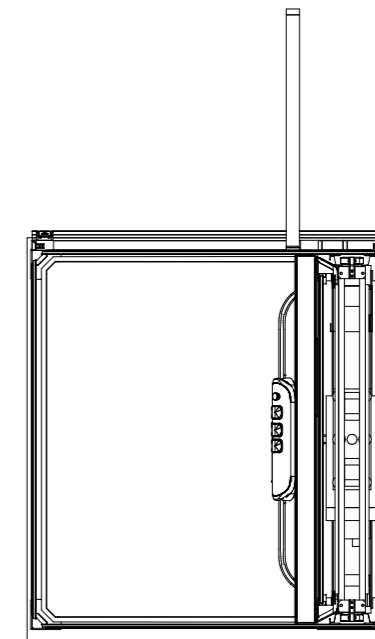
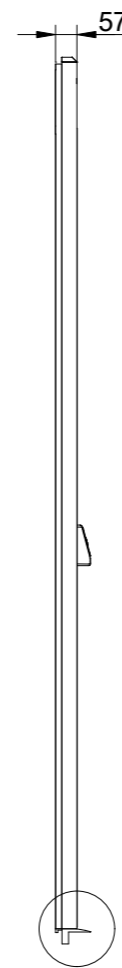
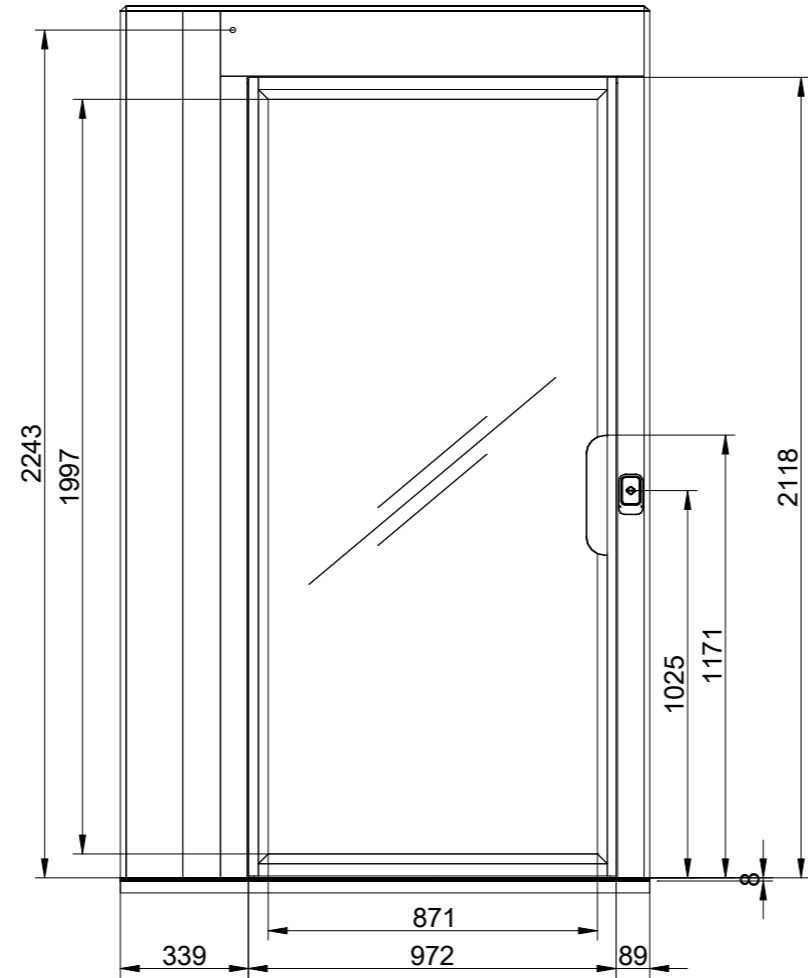
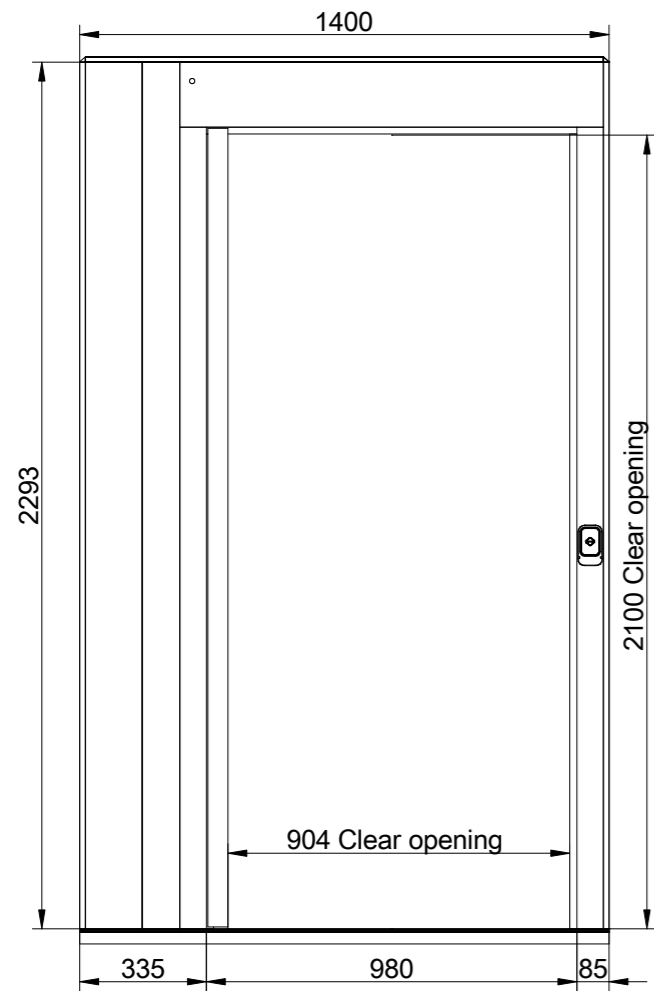

Scale: 1:30

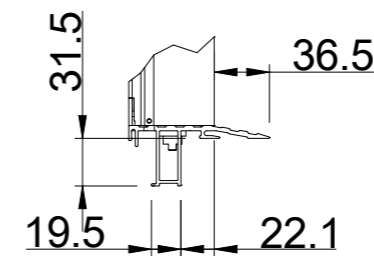
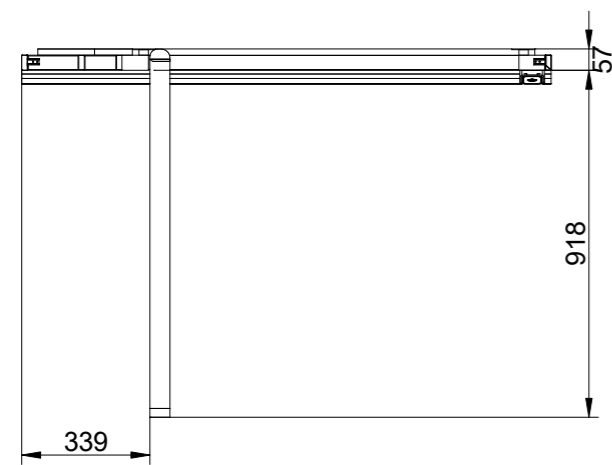

A (1:5)

Landing	Door type
0	Panoramic Plus
1	Panoramic Plus

Approved by builder:

European view placement:



Tender no
202307101774

Gen. Tolerances
SS-ISO 27681-1 m

Principal drawing
1 - 1025*1450
Landing information
Johanna Aaw Kalea 1025x450
Date 2023-07-10
05:59
sheet 5 of 6
Scale: A3, 1:50

6 5 4 3 2 1

Platform layout
Scale: 1:15

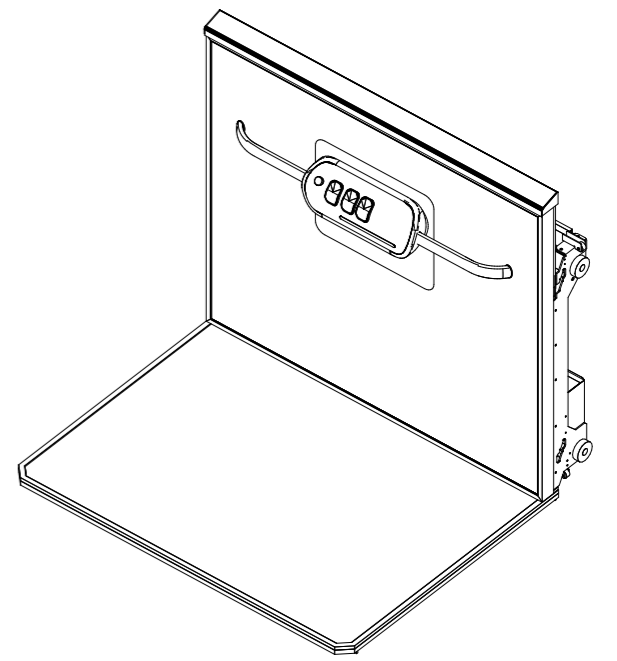
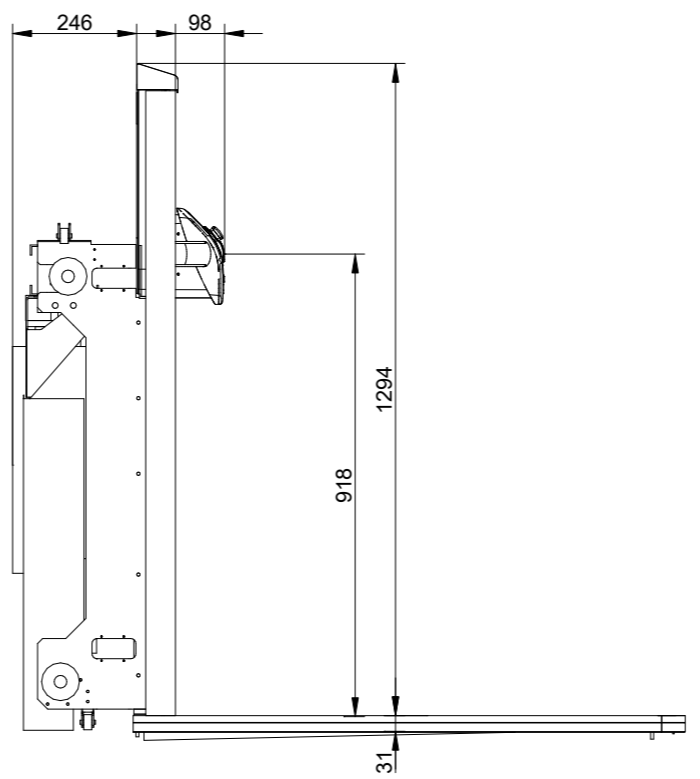
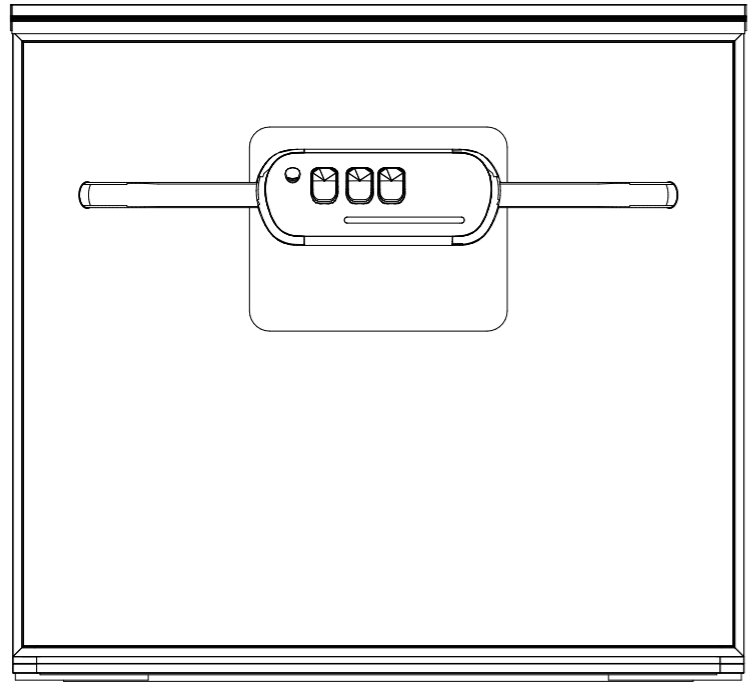

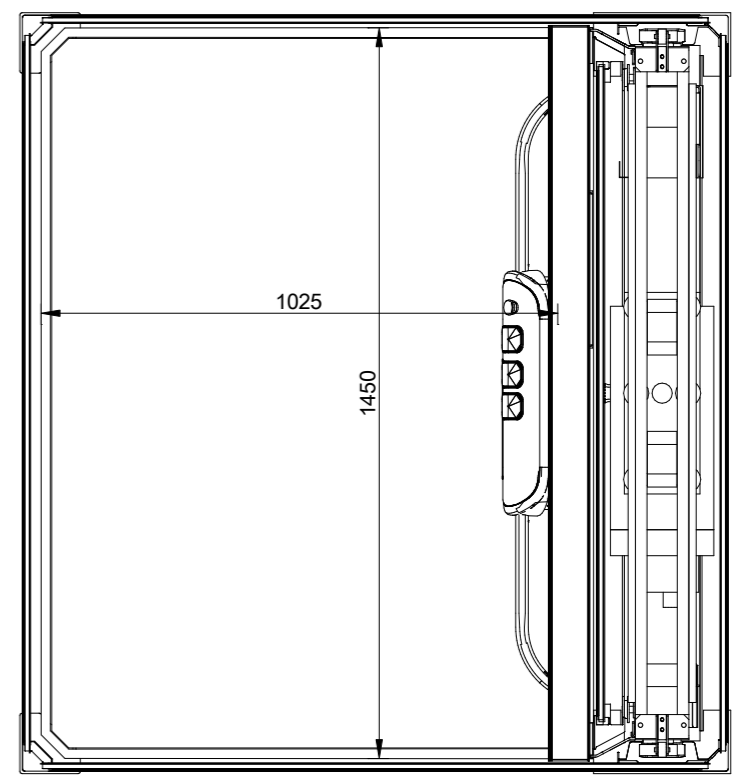

Platform dimensions
Scale: 1:15

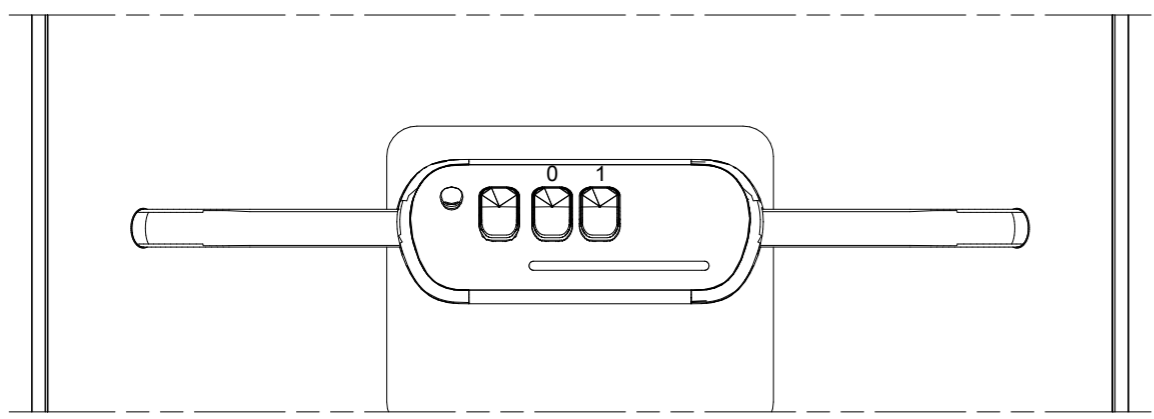

Button layout
Scale: 1:10



Approved by builder: _____		Tender no 202307101774		Principal drawing 1 - 1025*1450	
European view placement: 		Gen. Tolerances SS-ISO 27681-1 m	Date 2023-07-10 05:59	sheet 6 of 6	Scale: A3, 1:50

6 5 4 3 2 1

D

D

C

C

B

B

A

A